

REAR WHEEL/BRAKE/
FINAL DRIVE/SUSPENSION

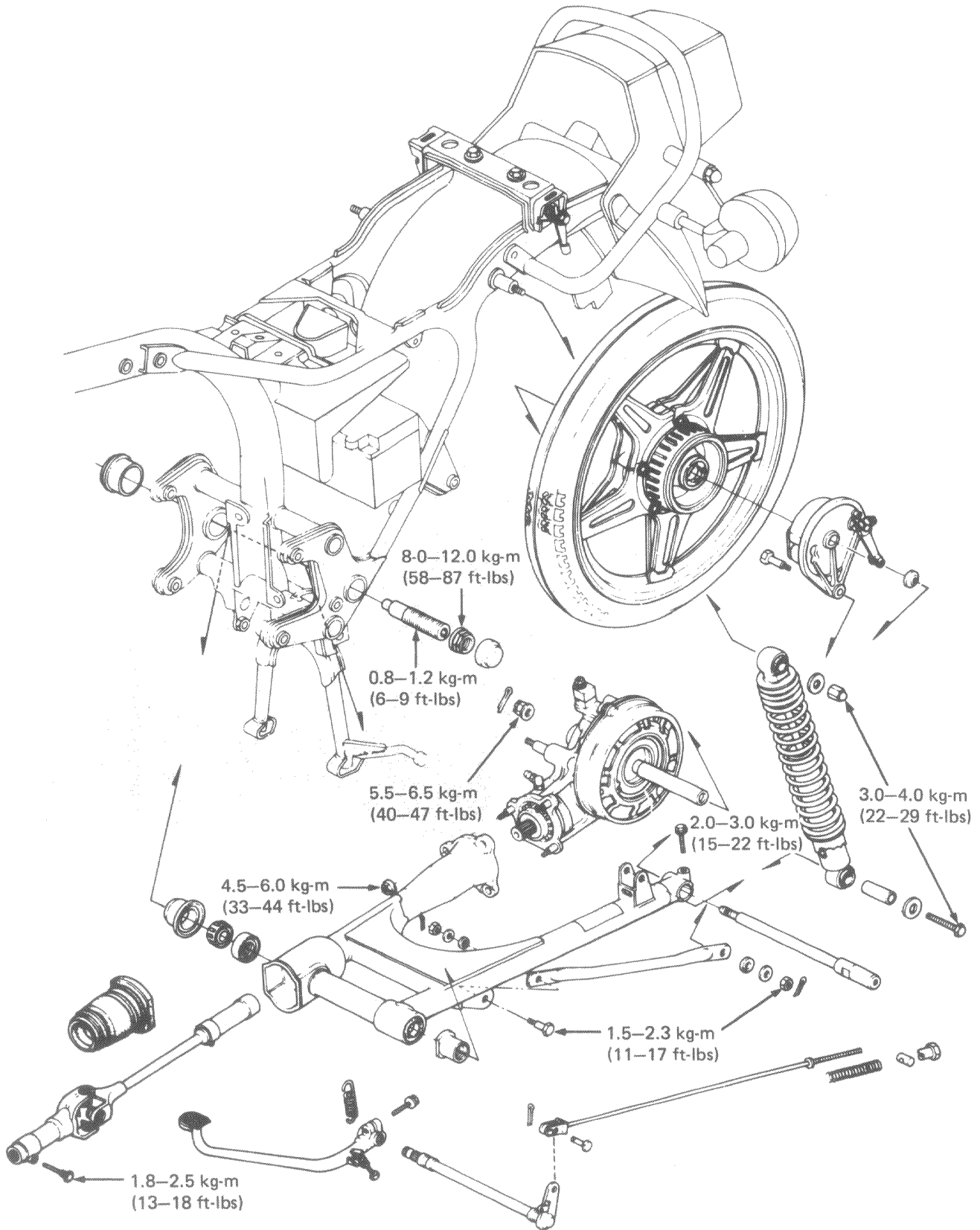

HONDA
CX500





SERVICE INFORMATION	14-1
TROUBLESHOOTING	14-2
REAR WHEEL REMOVAL/ DISASSEMBLY/ASSEMBLY	14-3
REAR BRAKE PANEL	14-7
REAR WHEEL INSTALLATION	14-8
SHOCK ABSORBER	14-9
FINAL DRIVE	14-12
REAR FORK/PROPELLER SHAFT	14-23

SERVICE INFORMATION

• WORKING PRACTICE

Do not remove the rivets, nuts and pins from the rim, spoke plates and hub, since they cannot be disassembled.

Do not ride on the rim or try to bend the wheel.

Avoid damaging the aluminum alloy rim.

Check that the tire and rim are free from damage as the tire is tubeless.

When removing the tire from the rim, use the special tools "TIRE LEVER" and "RIM PROTECTOR" to prevent damage to the rim.

For tubeless tire repairs, see the "HONDA MOTORCYCLE TUBELESS TIRE REPAIR MANUAL".

• SPECIAL TOOLS

Special tools

TIRE LEVER	07772-0020100
RIM PROTECTOR	07772-0020200
FINAL RETAINER WRENCH	07910-3710000
RETAINER B WRENCH	07910-4150000
SOCKET BIT (10 mm)	07917-3710000
SLIDING WEIGHT	07936-3710200
PIVOT BEARING OUTER REMOVER	07936-4150000
MECHANICAL SEAL DRIVER ATTACHMENT	07945-4150200
RING GEAR DIS/ASSEMBLY TOOL SET	07965-4150000
CENTER SHAFT DIS/ASSEMBLY TOOL	07965-4150100
DIS/ASSEMBLY TOOL A	07965-4150200
DIS/ASSEMBLY TOOL B	07965-3710200
DIS/ASSEMBLY TOOL C	07965-3710300
PRELOAD INSPECTION TOOL	07998-4150000

Common tools

RETAINER WRENCH B	07710-0010200
RETAINER WRENCH BODY	07710-0010401
LOCK NUT WRENCH SOCKET (30 x 32 mm)	07716-0020400
EXTENSION BAR HANDLE	07716-0020500
PIN DRIVER (3.5 mm)	07744-0010300
BEARING DRIVER OUTER (42 x 47 mm)	07746-0010300
BEARING DRIVER OUTER (52 x 55 mm)	07746-0010400
BEARING DRIVER PILOT (15 mm)	07746-0040300
BEARING DRIVER PILOT (30 mm)	07746-0040700
BEARING DRIVER HANDLE (A)	07749-0010000
REAR SHOCK ABSORBER COMPRESSOR	07959-3290001

• SPECIFICATIONS

		STANDARD		SERVICE LIMIT	
Axle bend		—		0.2 mm	(0.008 in.)
Rear wheel runout	Radial	—		2.0 mm	(0.08 in.)
	Axial	—		2.00 mm	(0.08 in.)
Brake lining thickness		4.9 – 5.0 mm	(0.19 – 0.20 in.)	2.0 mm	(0.08 in.)
Rear brake drum I.D.		160.0 mm	(8.06 in.)	161.0 mm	(6.34 in.)
Shock absorber spring free length		249.3 mm	(8.07 in.)	245.5 mm	(8.05 in.)
Final gear backlash		0.08 – 0.18 mm	(0.0032 – 0.0071 in.)	0.25 mm	(0.0098 in.)



TROUBLESHOOTING

Wobble or Vibration

1. Distorted rim
2. Loose wheel bearing
3. Loose or distorted spokes
4. Faulty tire
5. Loose axle

Soft Suspension

1. Weak spring
2. Shock absorbers improperly adjusted
3. Weak rear damper

Hard Suspension

1. Shock absorbers improperly adjusted

Suspension Noise

1. Shock case binding
2. Loose fasteners

Poor Brake Performance

1. Improper brake adjustment
2. Fouled brake linings
3. Worn brake shoes
4. Worn brake shoe cam contacting faces
5. Worn brake drum
6. Improper engagement between brake arm and shaft serrations

Final drive gear noise

1. Oil level too low
2. Excessive backlash
3. Drive shaft splines damaged or worn
4. Insufficient lubricant



REAR WHEEL REMOVAL/ DISASSEMBLY/ASSEMBLY

• REAR WHEEL REMOVAL

Place the motorcycle on its center stand.
Remove the cotter pin and loosen the axle nut.

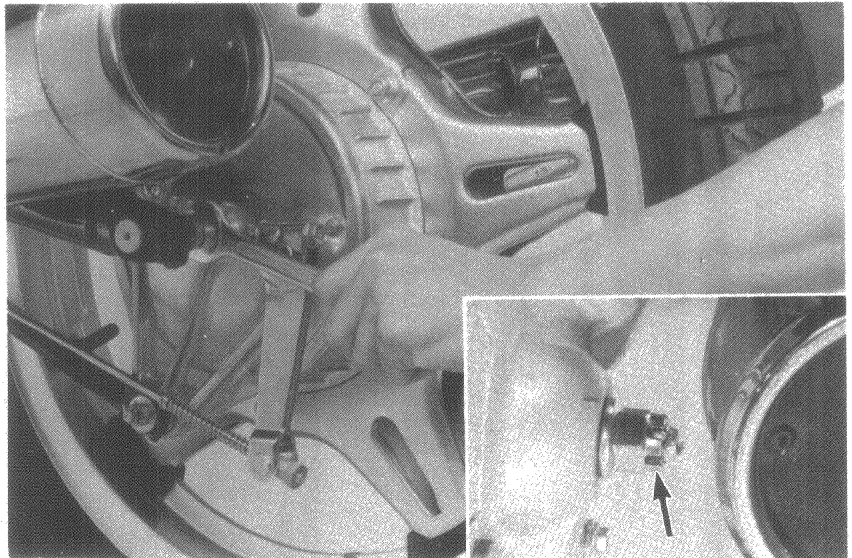

Loosen the axle holder bolt.
Remove the cotter pin and remove the brake
torque link.
Remove the brake adjusting nut and the brake
rod.

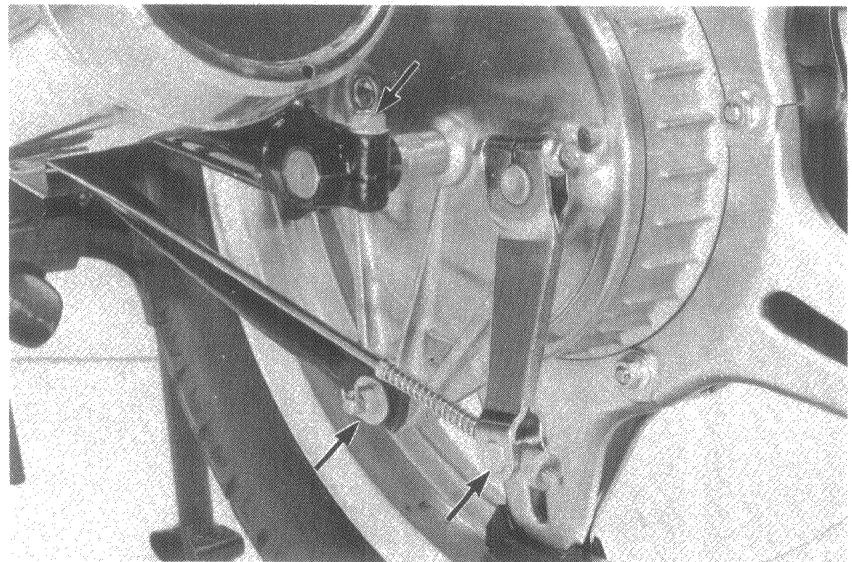

Remove the rear axle.

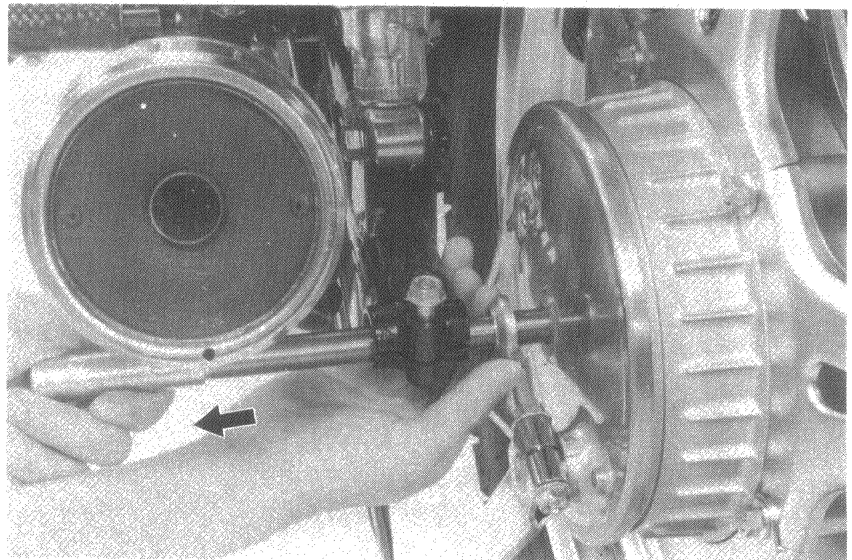



Push the rear wheel toward the left away from the final drive gear and then remove the wheel with the brake panel by pulling it backward.

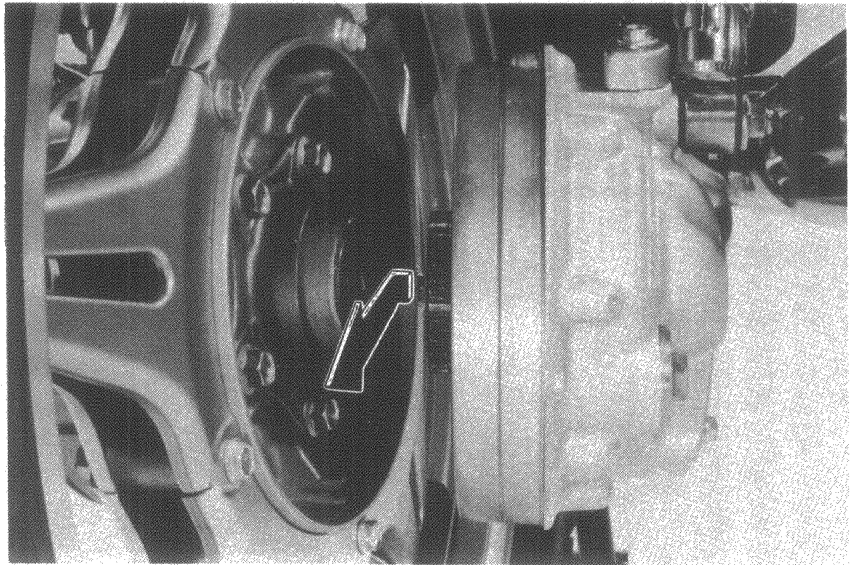

• **AXLE SHAFT BEND INSPECTION**

Set the axle shaft in V-blocks and measure the axle shaft runout. The actual axle bend is 1/2 of TIR (Total Indicator Reading).

SERVICE LIMIT: 0.2 mm (0.008 in.)

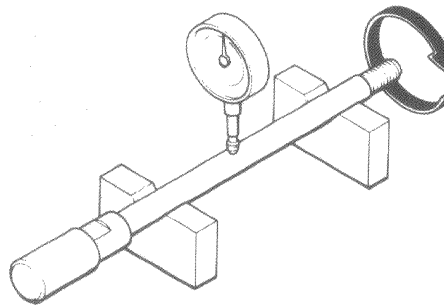

• **REAR WHEEL BEARING PLAY INSPECTION**

Rotate the rear wheel by hand.
Replace the wheel bearings with new ones if they are noisy or have excessive play.

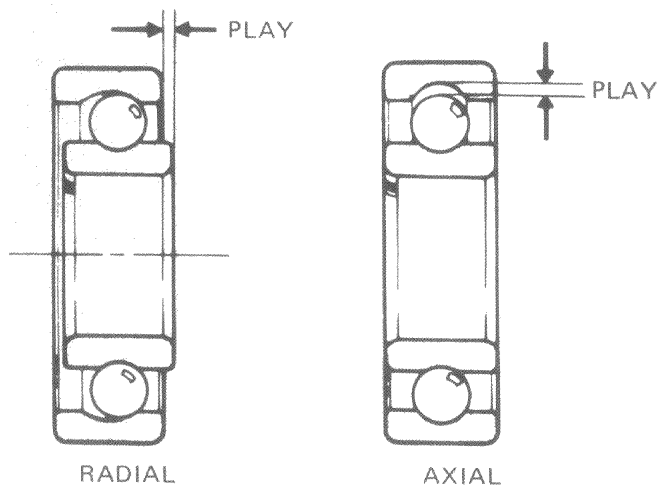



● REAR WHEEL RIM RUNOUT INSPECTION

Check the rim for runout by placing the wheel in a truing stand. Spin the wheel by hand, and read the runout using a dial indicator gauge.

NOTE

The COMSTAR WHEEL cannot be serviced and must be replaced if the above limits are exceeded.

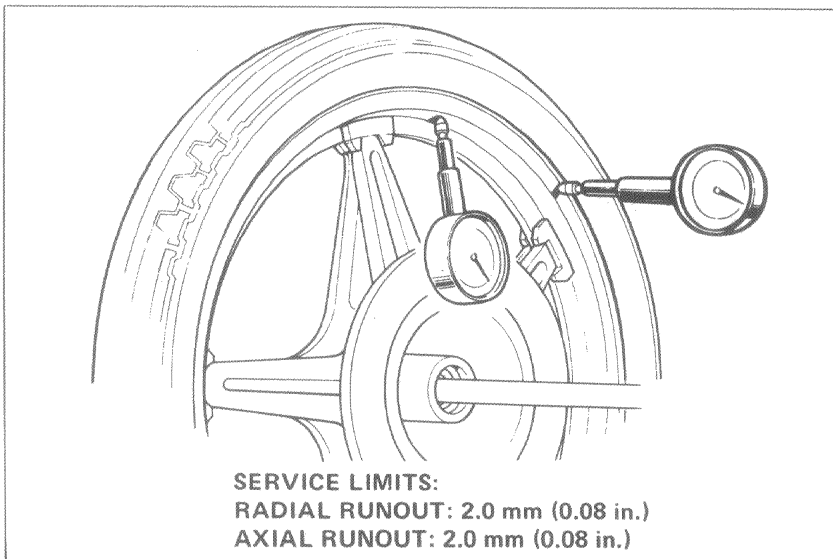

● REAR WHEEL DISASSEMBLY

Remove the bearing retainer.

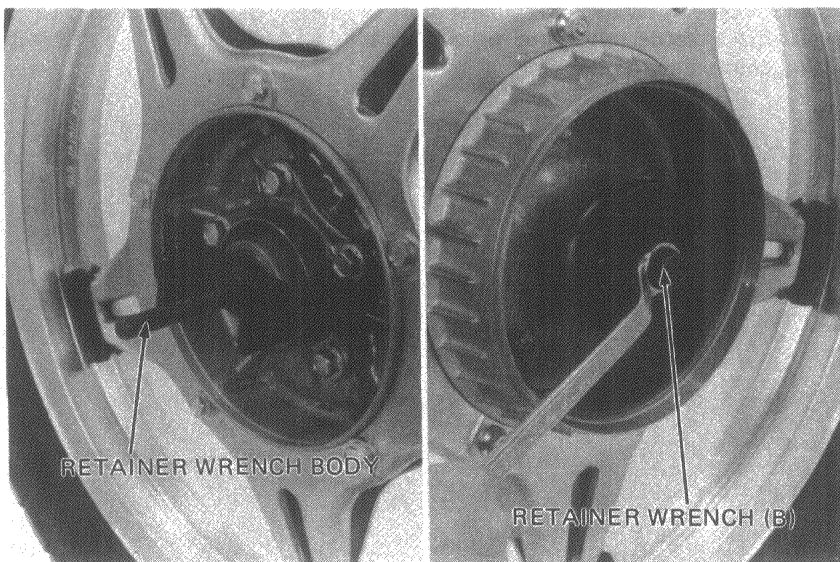

NOTE

Tubeless tires are standard.

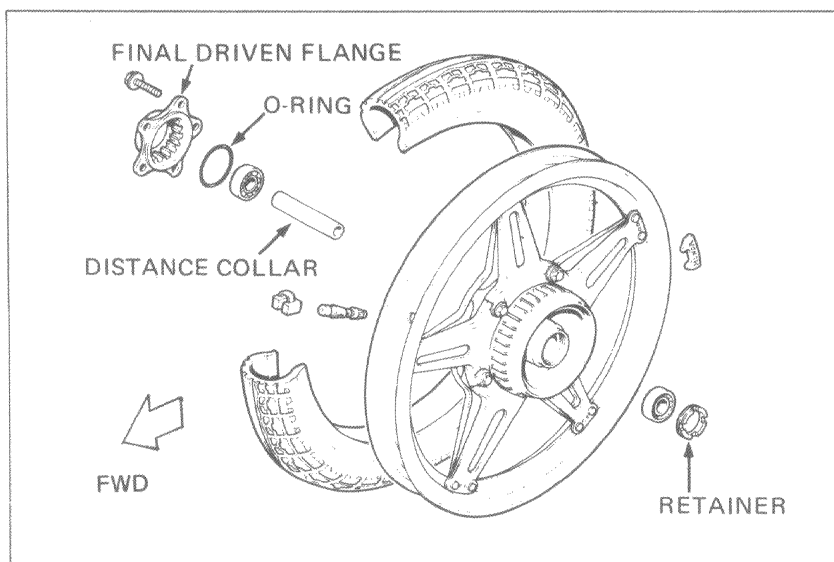



● REAR WHEEL ASSEMBLY

Pack all bearing cavities with grease and drive in the bearing with a bearing driver.
Drive the left (retainer side) bearing first.

NOTE

Drive the bearings squarely.

BEARING DRIVER HANDLE (A)
BEARING DRIVER OUTER (42 x 47 mm)
BEARING DRIVER PILOT (17 mm)

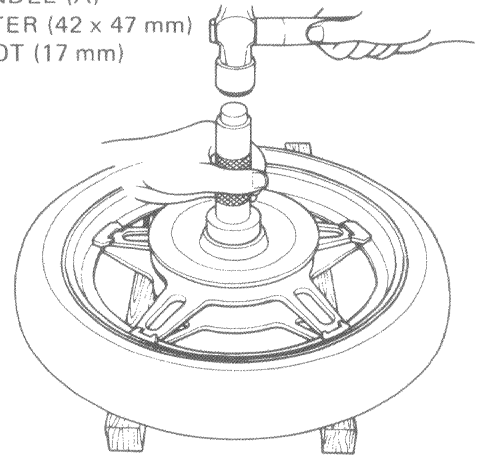

Install the bearing retainer and punch it.
Install the distance collar and drive the right bearing into place.

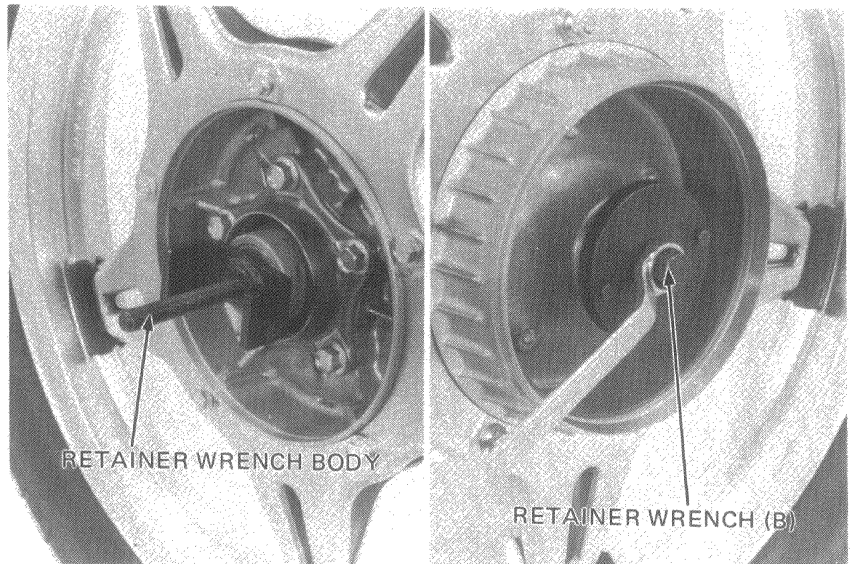

Install the O-ring and lubricate the splines and O-ring with lithium-based multipurpose grease.
Install the final driven flange.

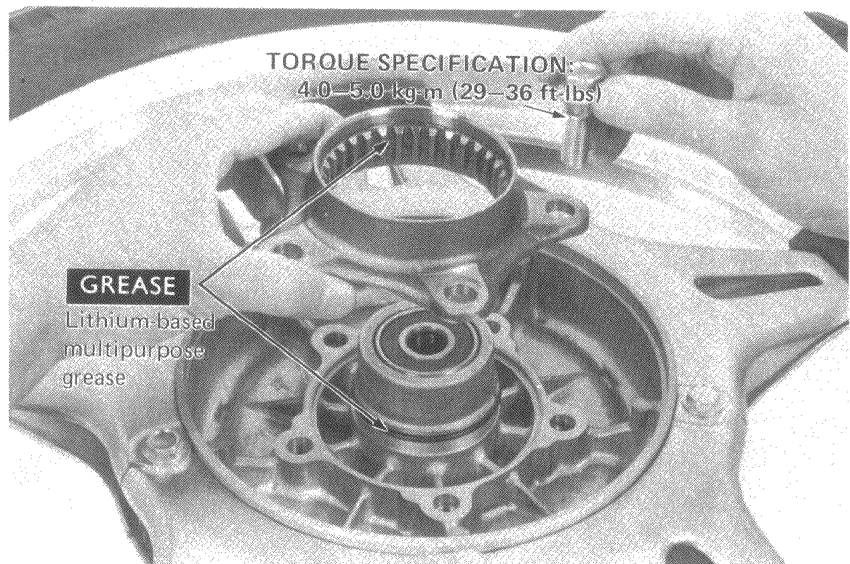



REAR BRAKE PANEL

- REAR BRAKE LINING THICKNESS

Measure the rear brake lining thickness.

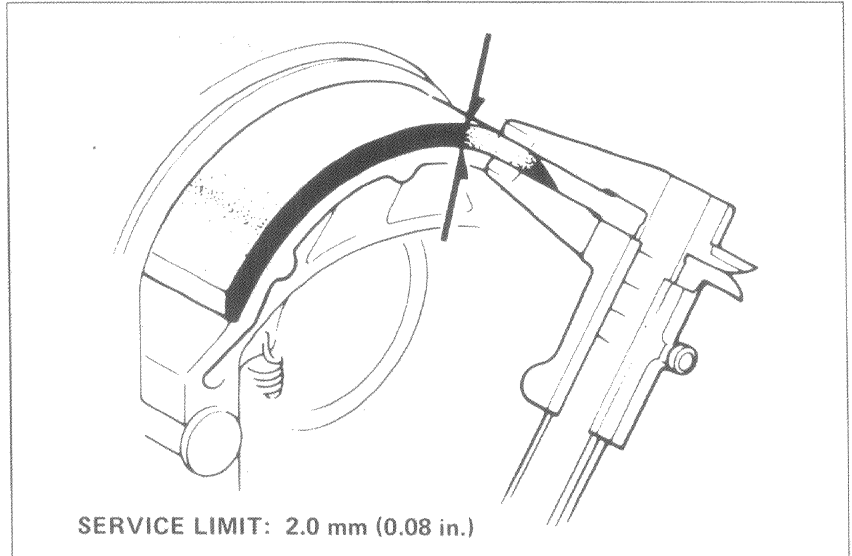

- REAR BRAKE SHOE REPLACEMENT

Remove the cotter pins.
Install new brake shoes.
Apply grease to the face of the brake cam.

WARNING

*Contaminated brake linings reduce stopping power.
Keep grease off the brake linings. Wipe the excess grease off the cam.*

NOTE

Make sure the punch mark on the brake arm aligns with the punch mark on the brake camshaft.

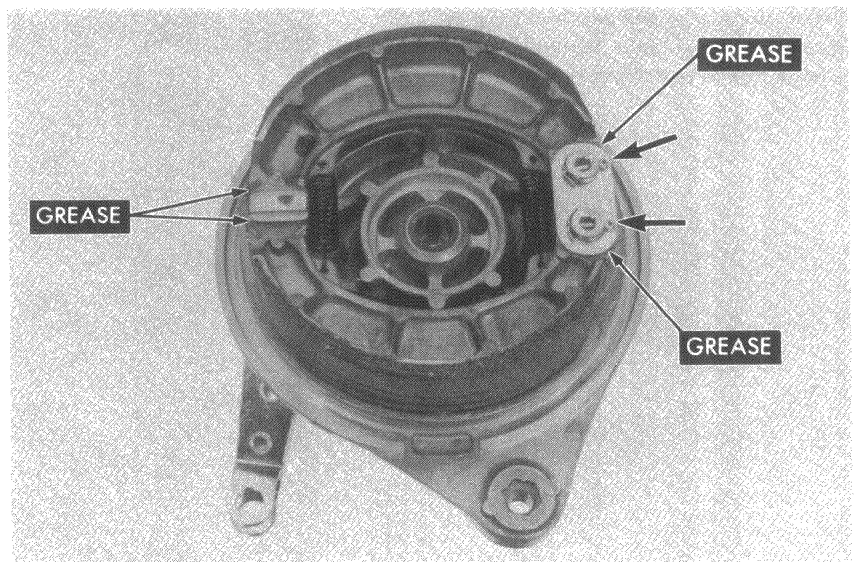

- BRAKE DRUM I.D. INSPECTION

Measure the brake drum I.D..

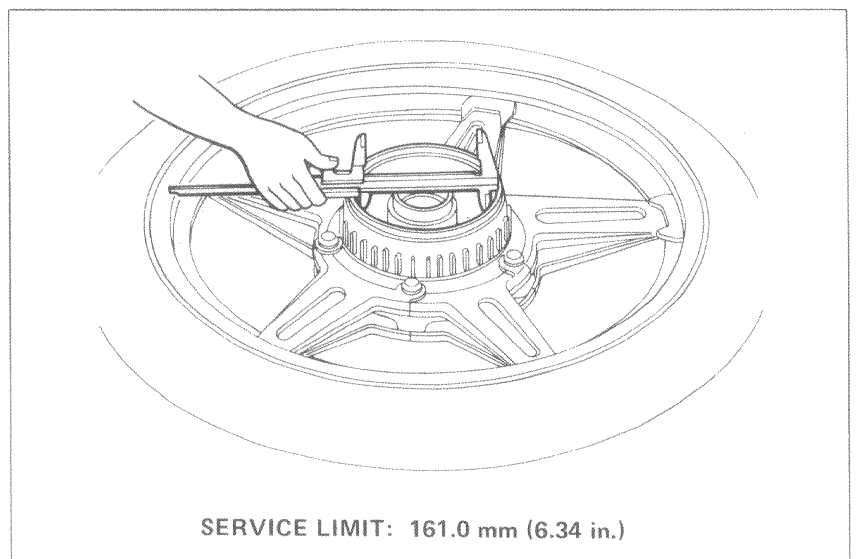



REAR WHEEL INSTALLATION

Apply lithium-based multipurpose grease to the final driven flange spline of the rear wheel and ring gear.

Insert the distance collar into the final gear case in the direction shown.

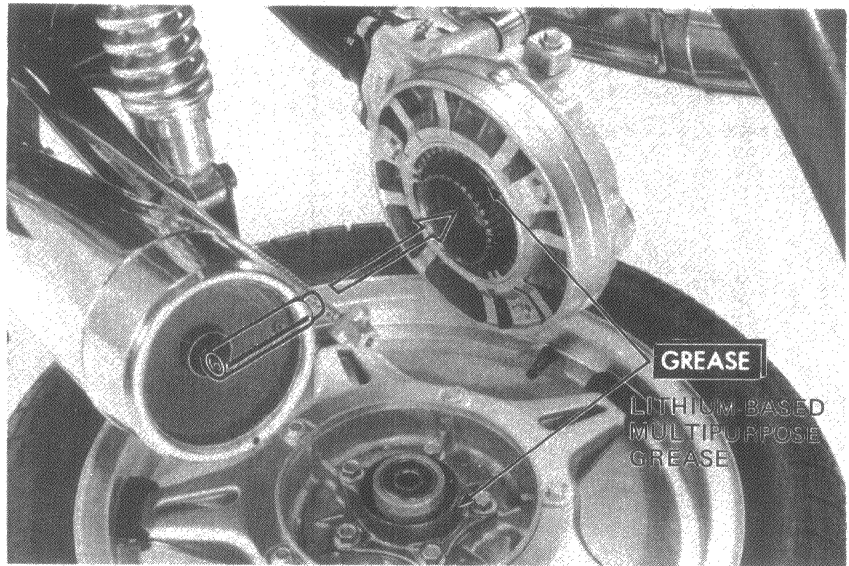

Install the rear wheel and brake panel.
Insert the rear axle through the swing arm, washer, brake panel and rear wheel.

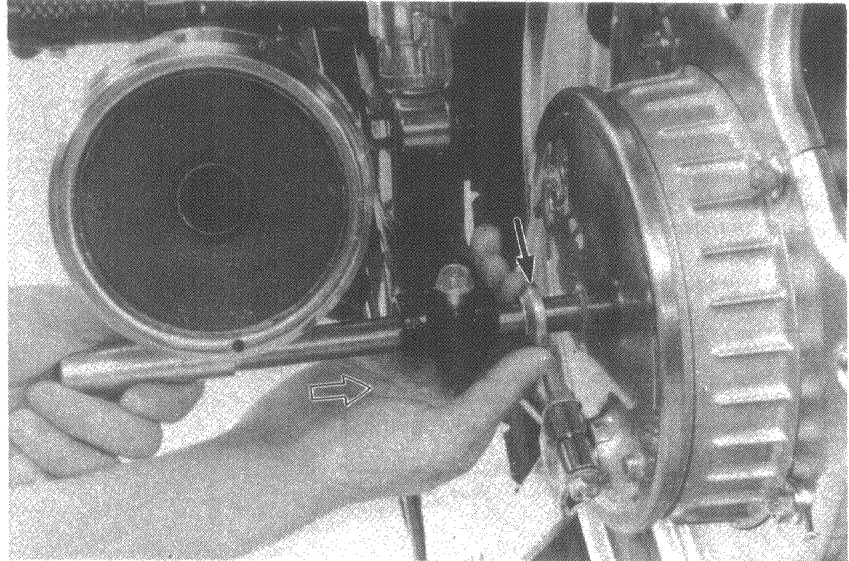

Connect the brake rod.

Install the brake torque link.

TORQUE SPECIFICATION:

1.5–2.3 kg-m (11–17 ft-lbs)

Torque the axle nut.

TORQUE SPECIFICATION:

3.4 – 4.0 kg-m (~~22–29 ft-lbs~~) (40 - 47 ft-lbs)

Tighten the axle fixing bolt.

TORQUE SPECIFICATION:

2.0–3.0 kg-m (15–22 ft-lbs)

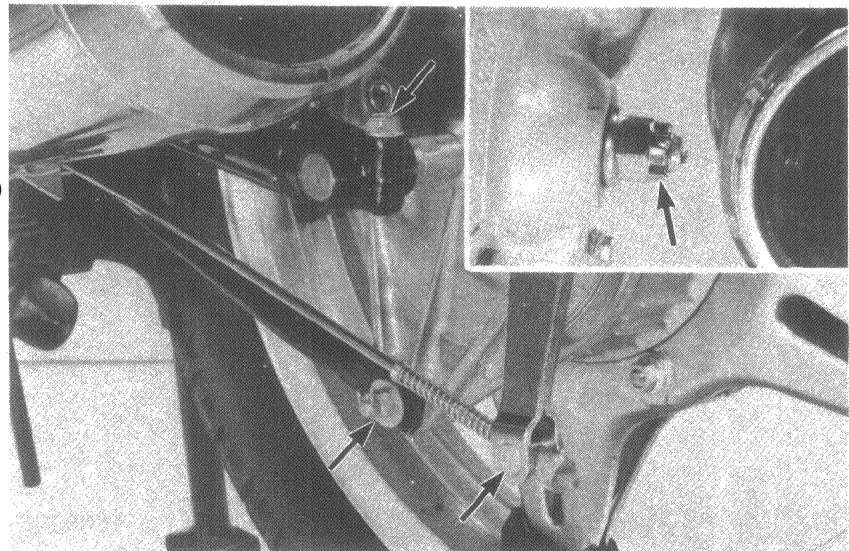



SHOCK ABSORBER

- SHOCK ABSORBER (RIGHT SIDE) REMOVAL

NOTE

Before removing the rear shock absorber, rotate the adjuster to the softest position.

Remove the upper and lower attaching nuts.
Remove the shock absorber.

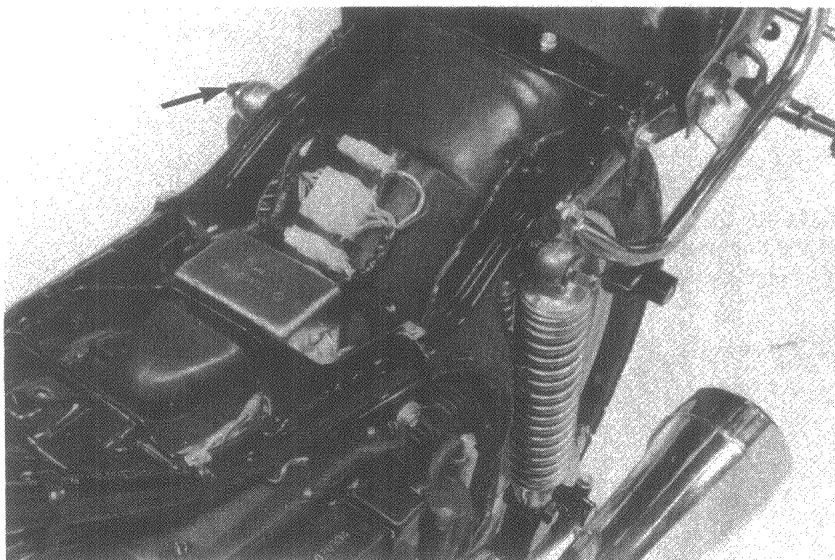

- SHOCK ABSORBER (LEFT SIDE) REMOVAL

Remove the upper attaching nuts and the upper parts of both rear shock absorbers from the holders.

Loosen the left side lower bolt and pull out the bolt while lifting the rear wheel.

Remove the shock absorber.

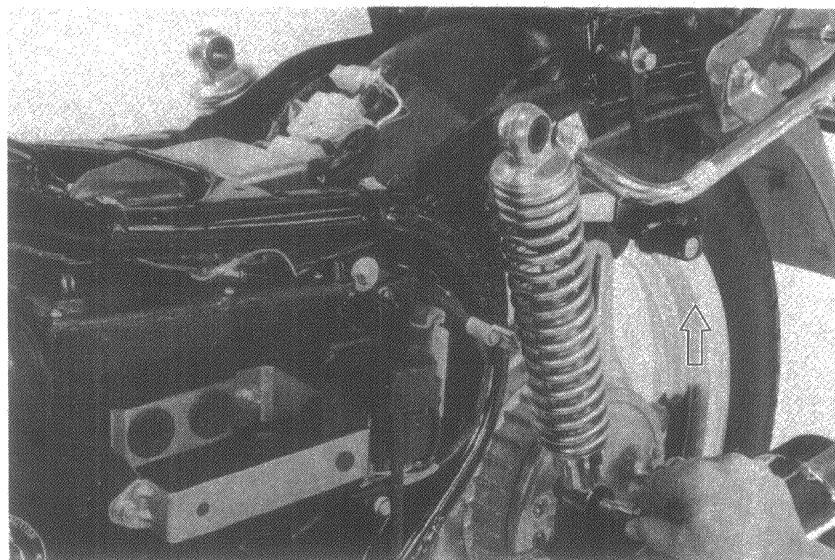

- SHOCK ABSORBER DISASSEMBLY

NOTE

Make sure that the shock absorber is in the softest position.

Set the rear cushion in the compressor as shown and compress the spring 30 mm by turning the compressor handle.

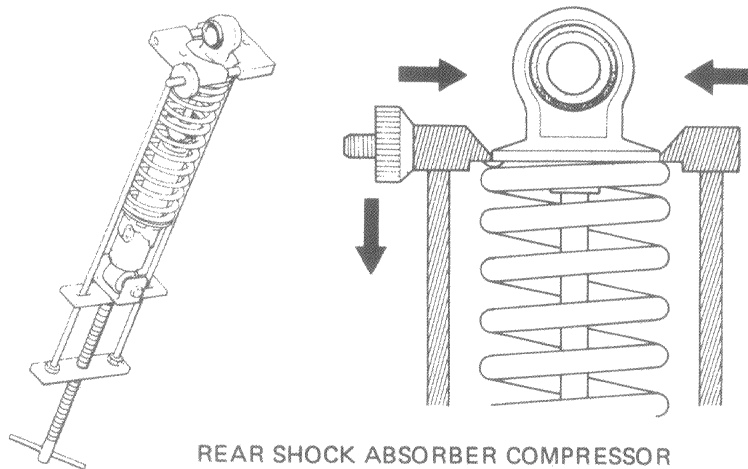

REAR SHOCK ABSORBER COMPRESSOR



Place the upper joint in a vise and pull out the rod.

NOTE

Loosen the holder nut to aid removal of the damper.

Separate the upper joint rotating the lock nut in the direction shown.

Remove the compressor.

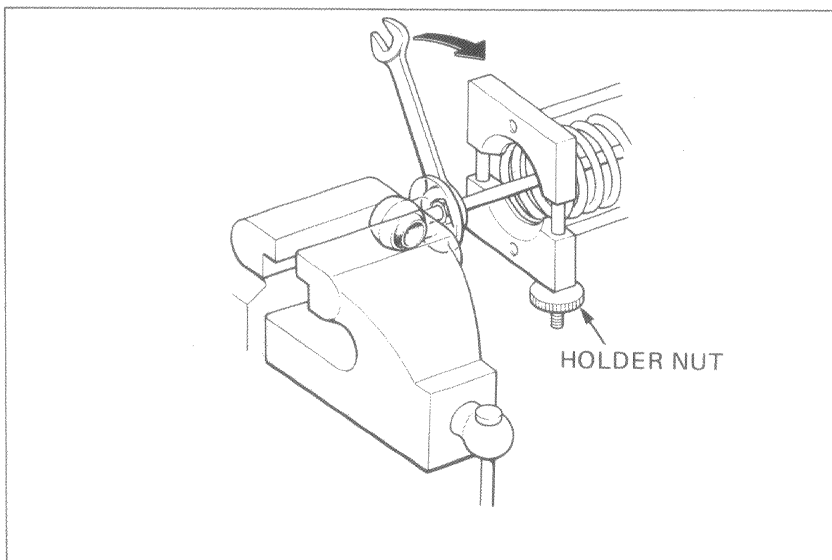

• **SHOCK ABSORBER SPRING FREE LENGTH**

Measure the rear shock absorber spring free length.

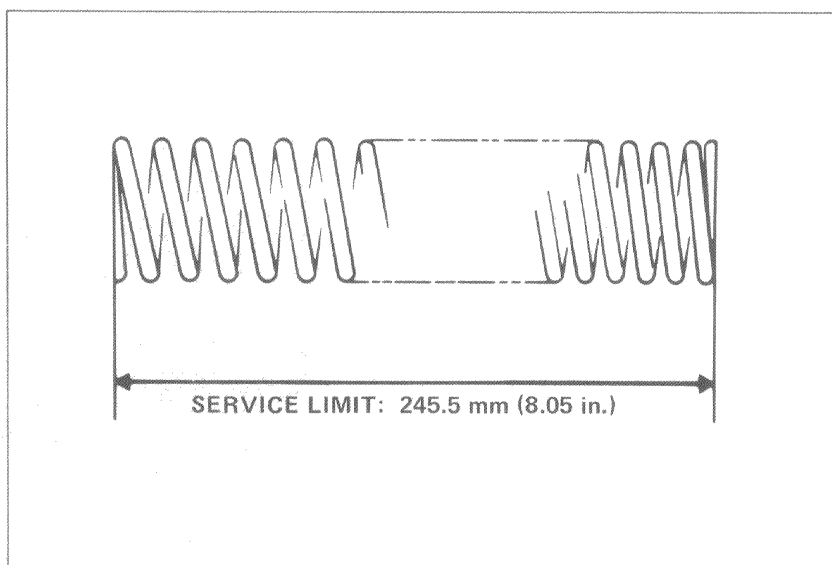

• **SHOCK ABSORBER ASSEMBLY**

Install the spring adjuster, the spring under seat, spring and stopper rubber on the damper.

NOTE

Install the spring with the tightly wound end facing up.

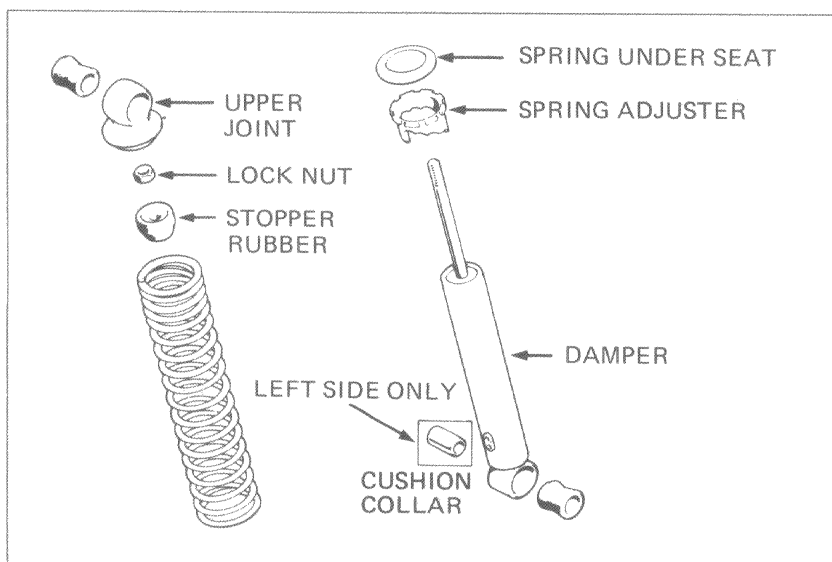



Apply locking agent to the rod threads and tighten the lock nut securely.
Attach the shock absorber compressor.

WARNING

Screw in the holder nut to prevent the spring from coming out of position.

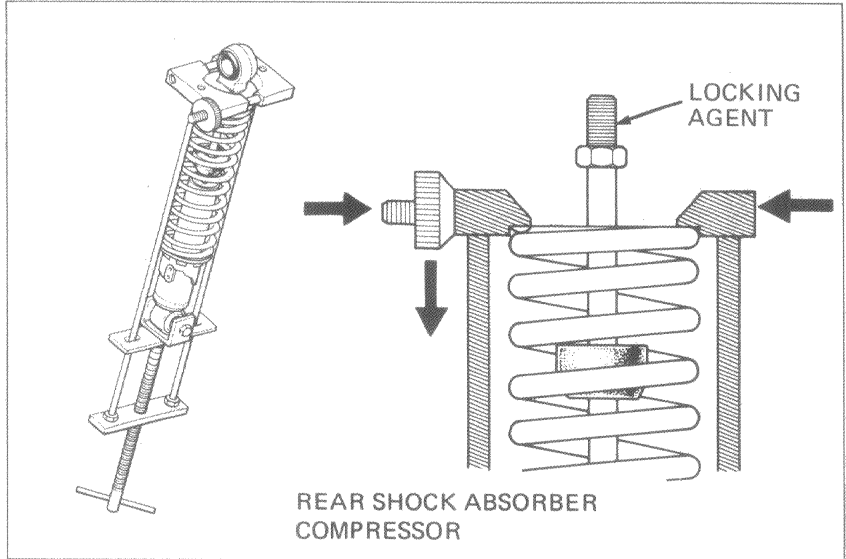

Apply locking agent to the rod threads.
Place the upper joint in a vise and tighten the rock nut securely.

NOTE

Check that the locknut is seated against the rod's bottom thread.

Align the spring with the upper joint by loosening the holder nuts while releasing the compressor.

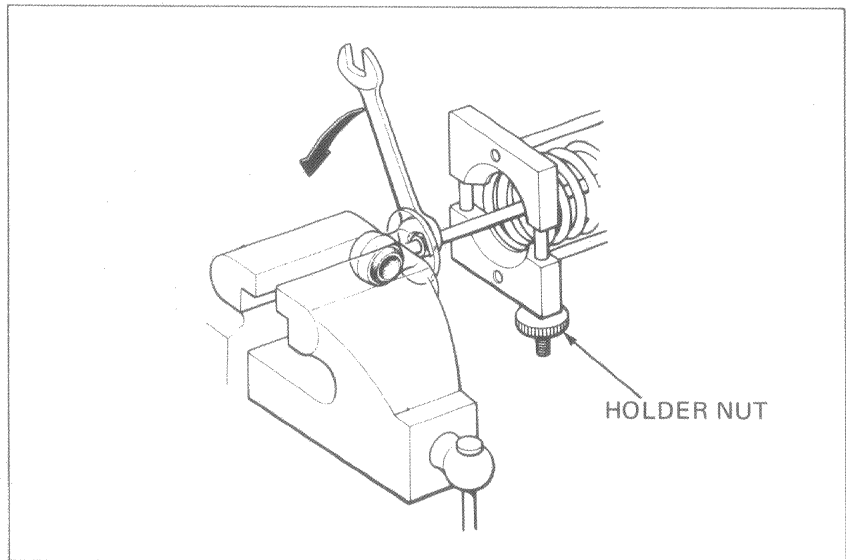

● **SHOCK ABSORBER
INSTALLATION**

Lift the rear wheel and install the left absorber lower bolt, with the right absorber removed.

TORQUE SPECIFICATION:
3.0 – 4.0 kg-m (22 – 29 ft-lbs)

Position the right and left shock absorber adjusters equally.

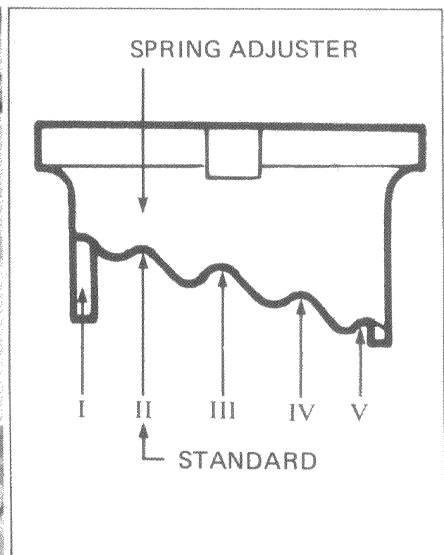
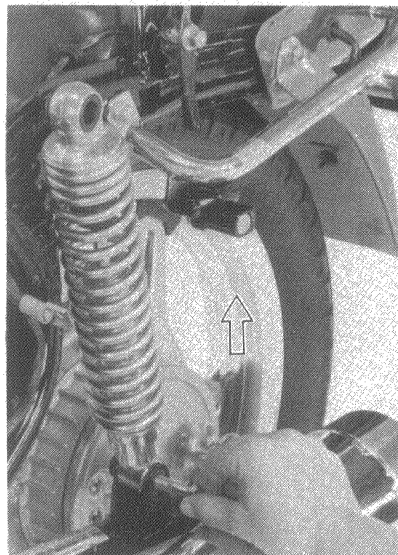



FINAL DRIVE

• FINAL GEAR CASE REMOVAL

Place the motorcycle on its center stand.
Remove the rear wheel. (Page 14-3)
Remove the distance collar.
Remove the final gear case attaching nuts.
Remove the final gear case from the swing arm and remove the drive hub from the shock absorber.

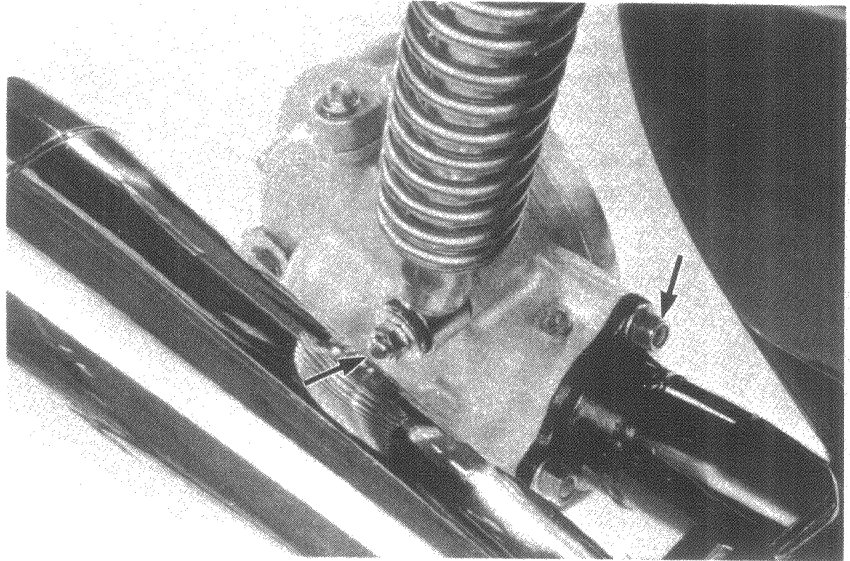

• BACKLASH INSPECTION

Place the final gear case in a vise.

NOTE

Do not tighten the drive hub in the vise excessively.

Set up a dial indicator on the ring gear teeth. Install the preload inspection tool (P/N 07998-4150000) to hold the pinion gear securely. Hold the pinion gear spline securely, rotate the ring gear until gear slack is taken up. Turn the ring gear back and forth to read backlash.

Measure 3-5 splines.

SERVICE LIMIT: 0.25 mm (0.0098 in)

NOTE

Ring gear control spacers are available in increments of 0.040 mm. Each change in spacer thickness will decrease or increase backlash 0.015 mm.

If the backlash is too great use a thinner spacer.
If the backlash is too little use a thicker spacer.

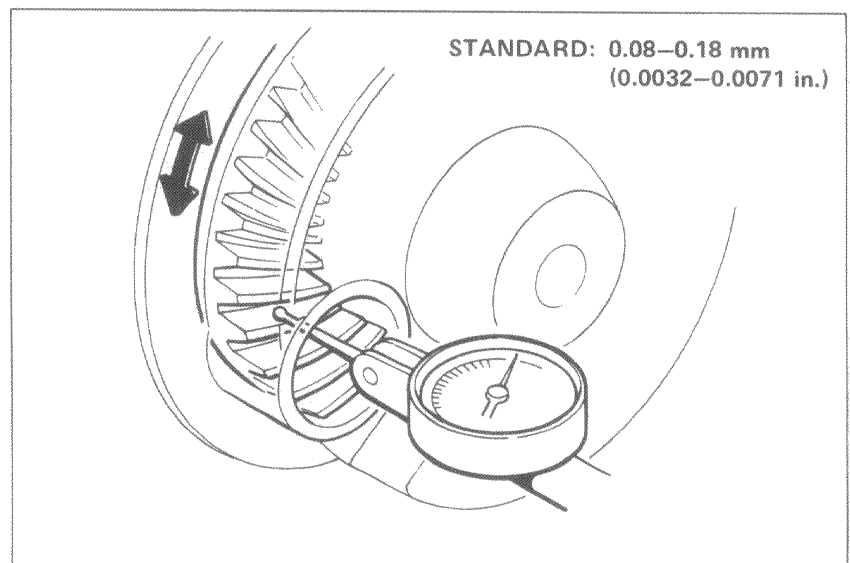
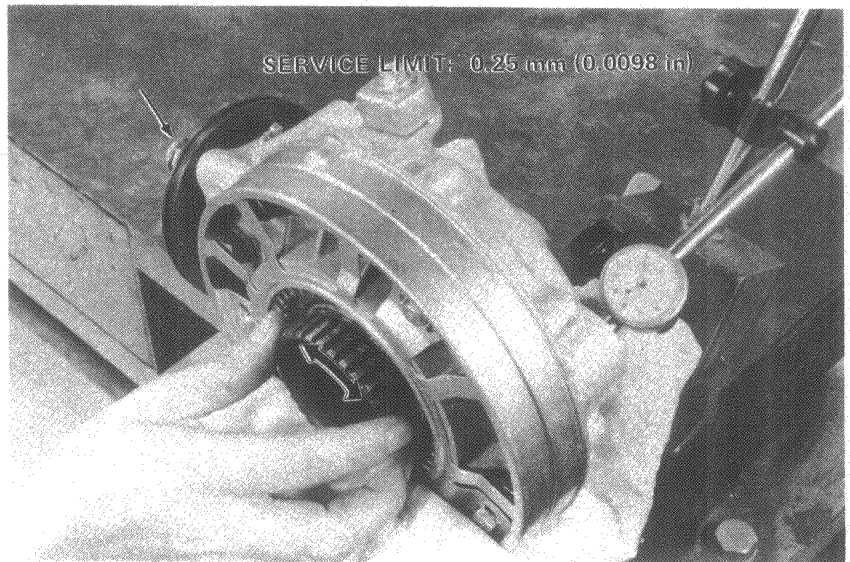



• **RING GEAR REMOVAL**

Straighten the tabs of the lock plates and remove the dust guard plate.

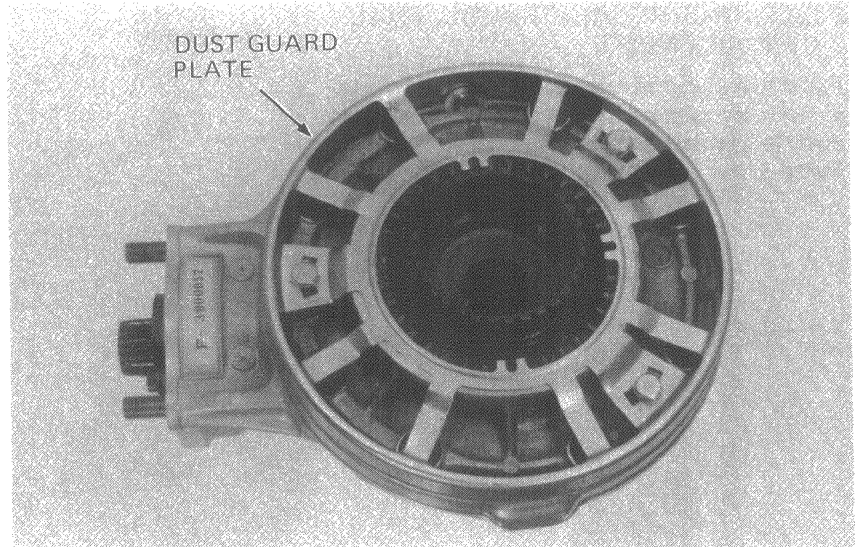

Remove bearing retainer A with the O-ring and oil seal.
Remove the eight left gear case cover bolts and left gear case cover with the ring gear and bearing.
Remove the ring gear spacer from the case.

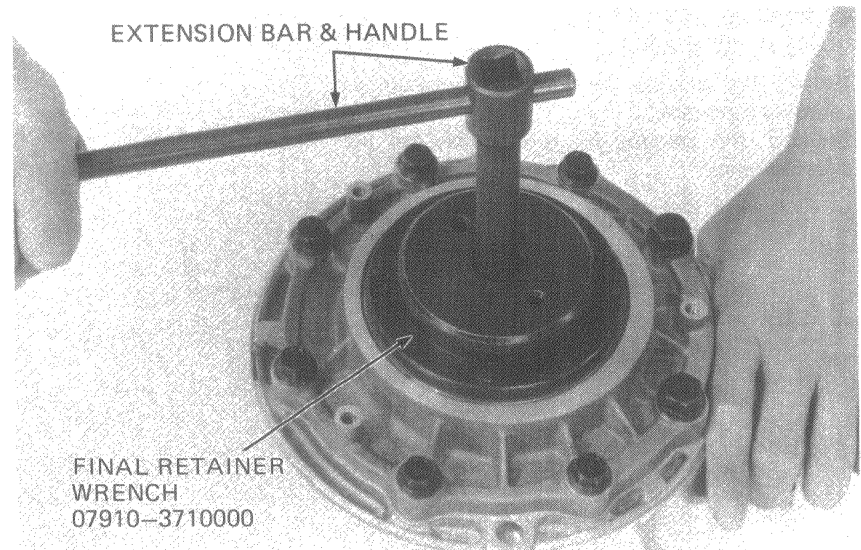

Separate the left case cover from the ring gear and bearing.

NOTE

When separating the left case cover from the ring gear and bearing, tap it lightly with a soft hammer. Avoid damaging the cover and bearing.

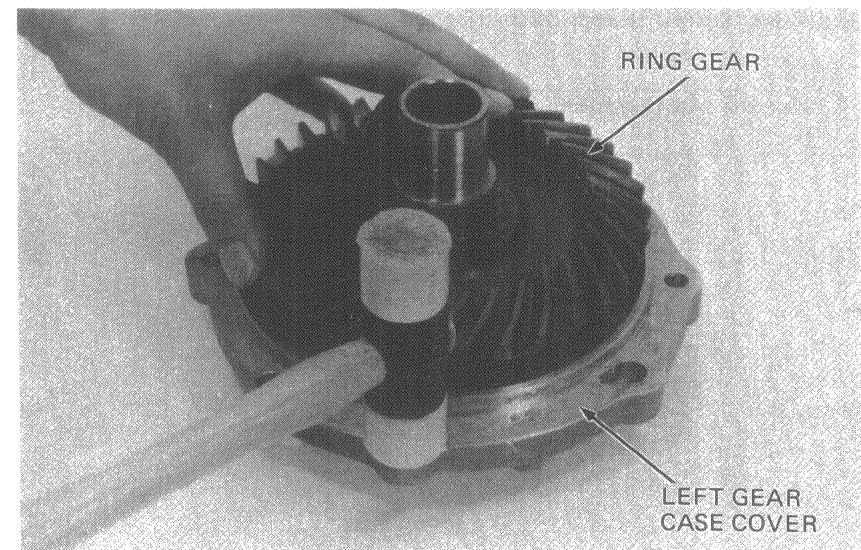



• BEARING RETAINER A OIL SEAL
REPLACEMENT

Inspect the bearing retainer A oil seal. If the lip is worn or damaged, or if the spring band is distorted, replace the oil seal.
Install a new O-ring.

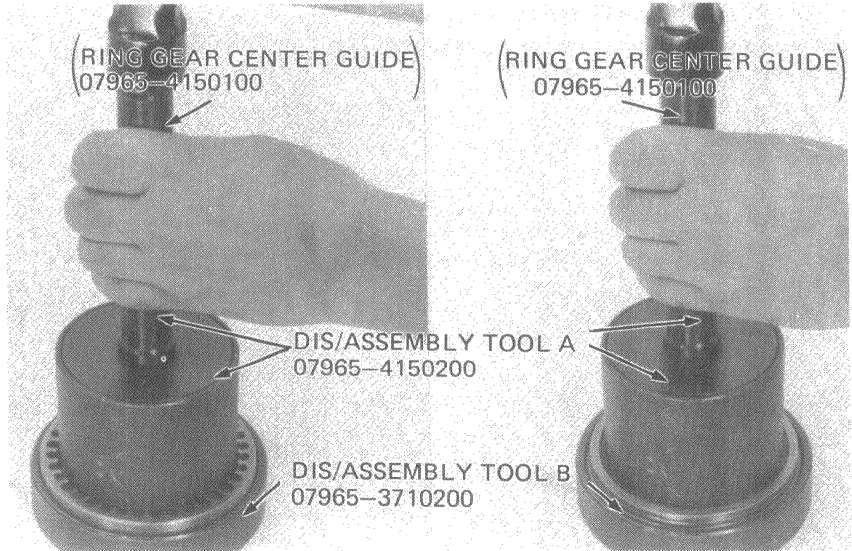

• RING GEAR BEARING
REPLACEMENT

Inspect the bearing for smooth operation by spinning it by hand.
Replace the bearing if it is noisy or has excessive play.

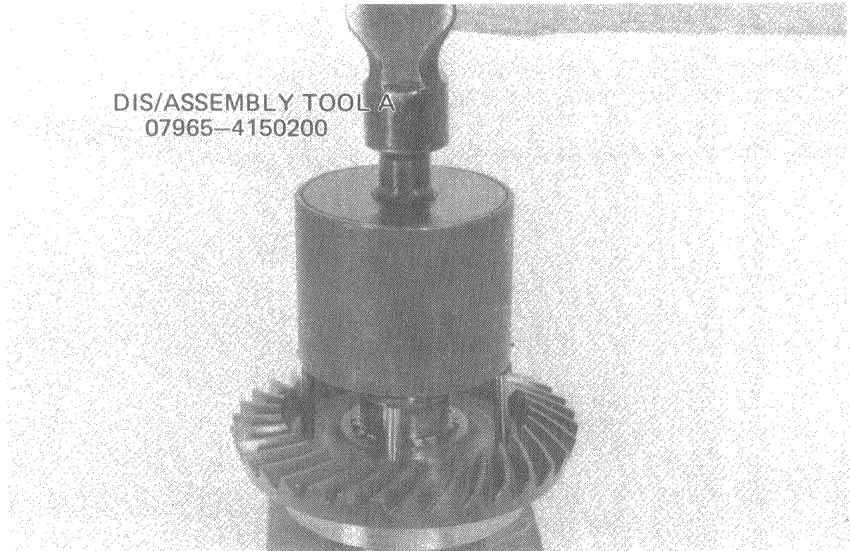

Install the ring gear bearing on the ring gear.

NOTE

Drive the bearing in until it seats properly.

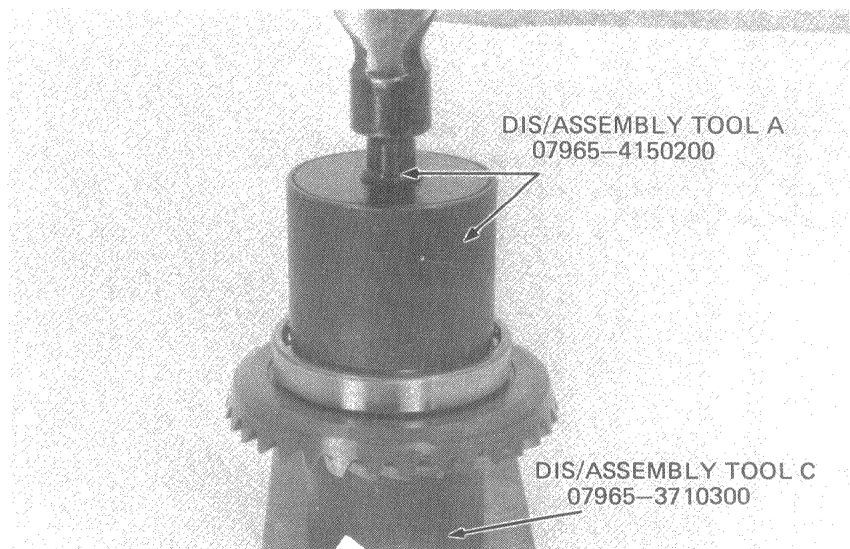



• BREATHER SYSTEM MAINTENANCE

Check the breather hole for clogging. Clean if necessary.

NOTE

Clean around and inside of the breather cap.

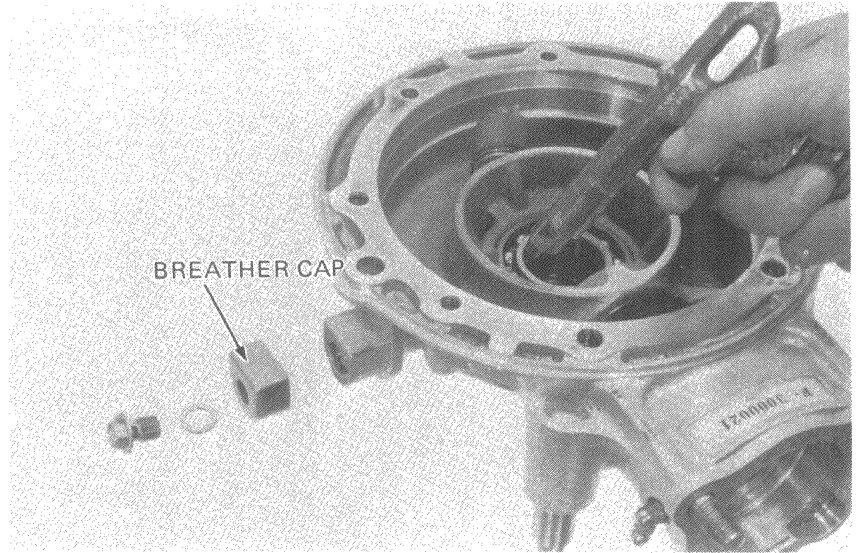

• RING GEAR OIL SEAL REPLACEMENT (GEAR CASE SIDE)

Inspect the ring gear oil seal for leakage. Replace the oil seal if the lip is damaged or if the spring band is distorted. If replacement is necessary, it is necessary to remove the ring gear bearing.

NOTE

Drive the oil seal in squarely.

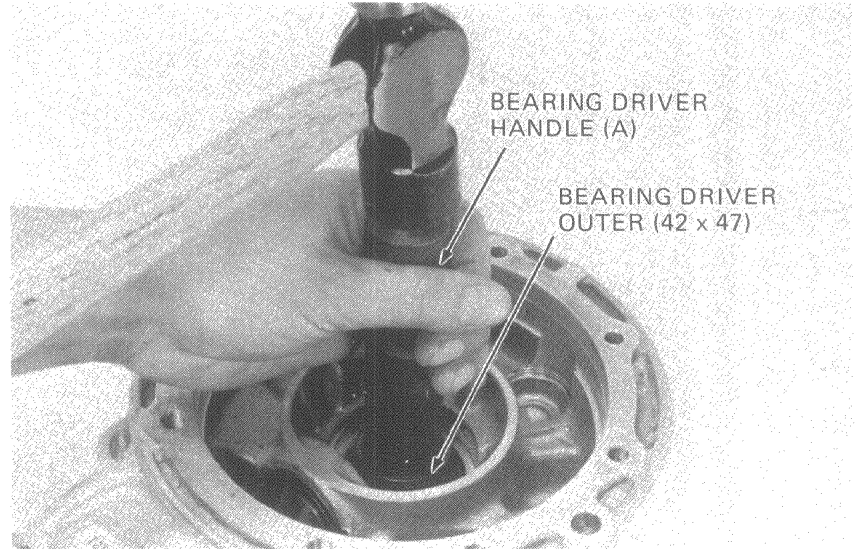

• RING GEAR BEARING REPLACEMENT (GEAR CASE SIDE)

Inspect the bearing for smooth operation spinning it by hand. Replace the bearing with a new one if it is noisy or has excessive play.

NOTE

Drive the bearing in squarely.

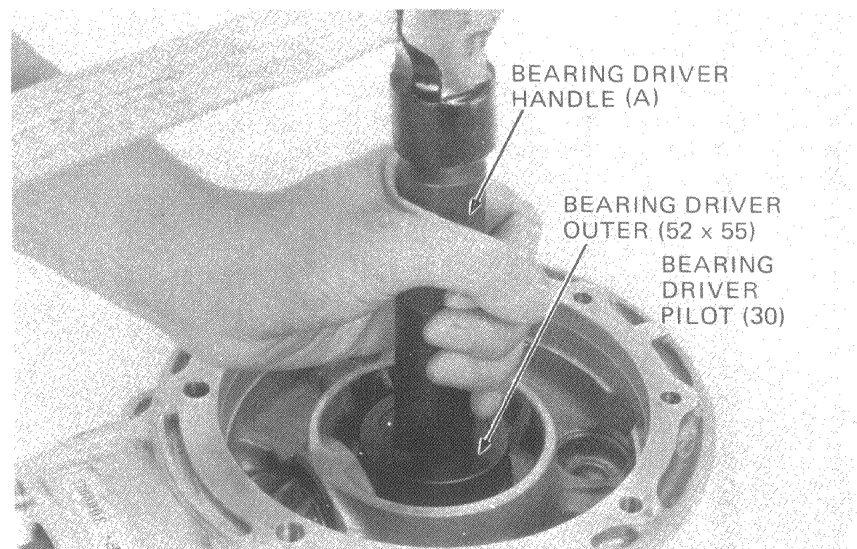



• BEARING RETAINER B REMOVAL

Remove the bearing retainer B lock washer.

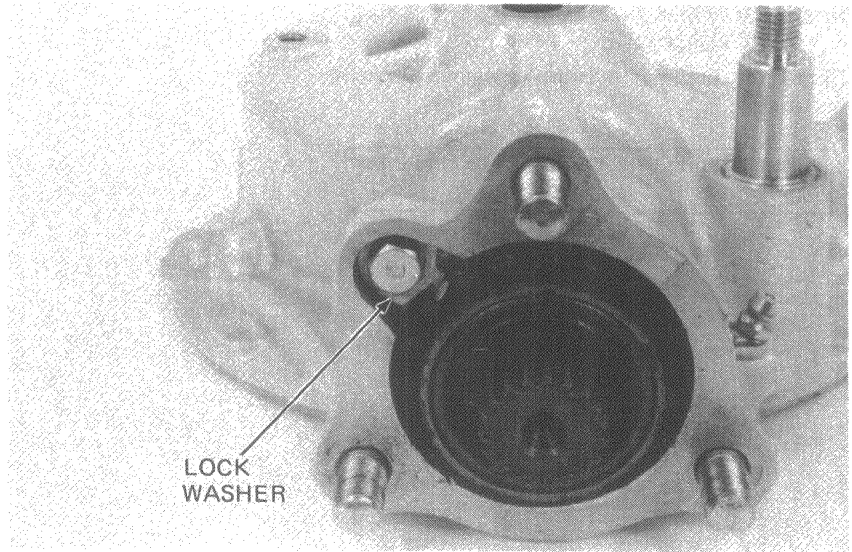

Remove the bearing retainer B.

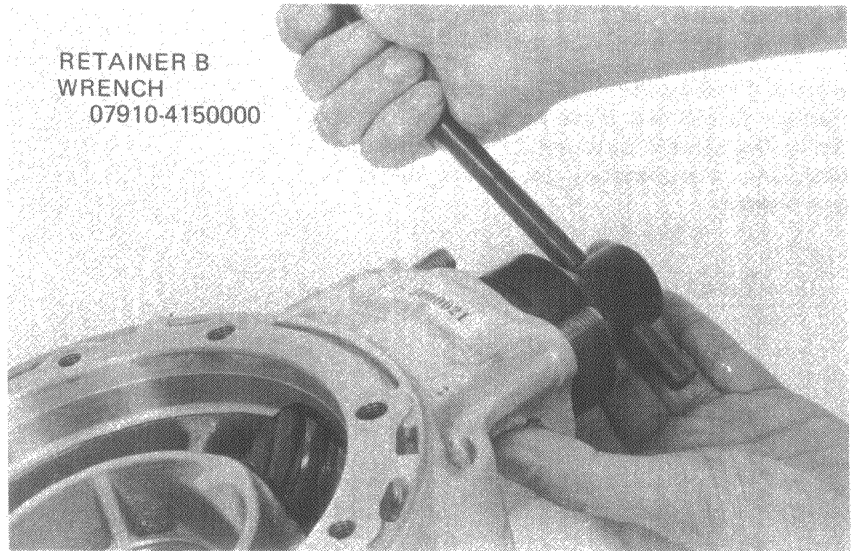

• BEARING RETAINER B OIL SEAL,
O-RING REPLACEMENT

Inspect the bearing retainer B oil seal. Replace the oil seal if the lip is worn or damaged, or if the spring band is distorted. Replace the O-ring with a new one.

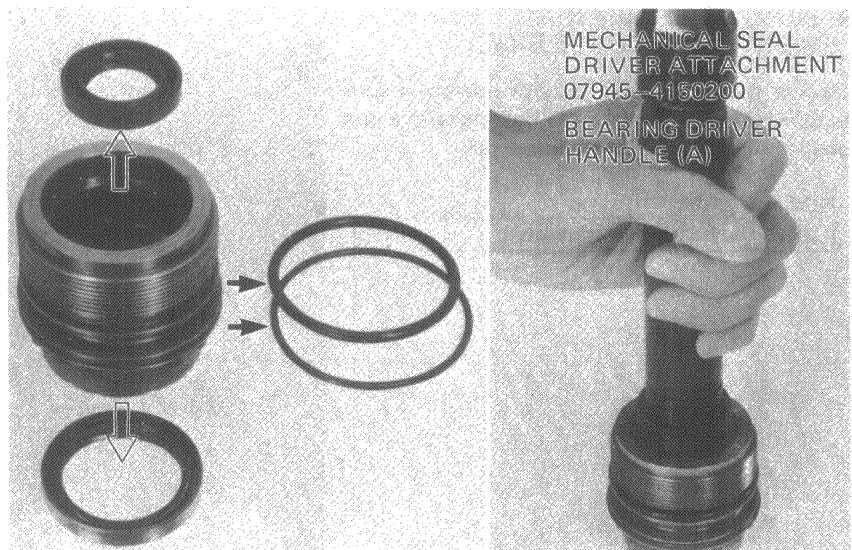



• BEARING RETAINER B
INSTALLATION

Apply a thin coating of lithium-based multi-purpose grease to the inside of the gear case to prevent damage to the bearing retainer B O-ring during installation.

Lubricate the lip of the oil seal with lithium-based multipurpose grease.

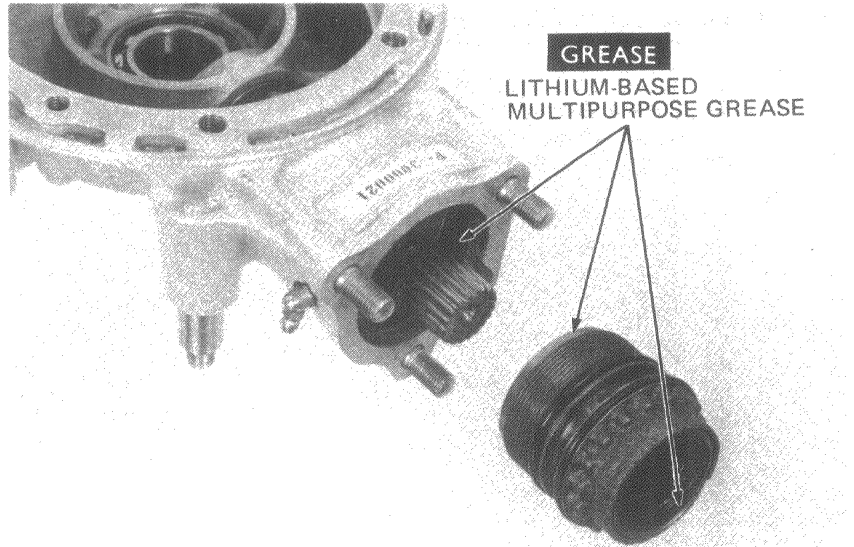

Torque the bearing retainer B.

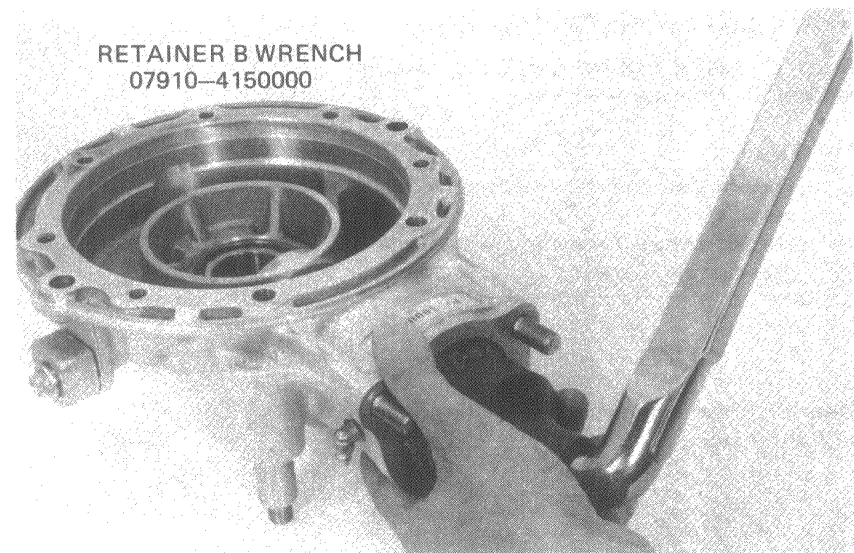

Inspect the pinion preload.

Run a string through a bolt hole in the pinion gear holder and wind it around the outside of the groove.

Attach a spring scale to the string and measure the force needed to turn the holder at one revolution per second.

NOTE

Torque required to begin pinion movement may exceed preload limits.

PINION PRELOAD: 800-1,000 g
(1.76-2.2 lbs)

[4.0-5.0 kg-cm (3.48-4.32 in-lbs)]

If the pinion preload is out of specifications, reinstall the bearing retainer B and recheck the preload.

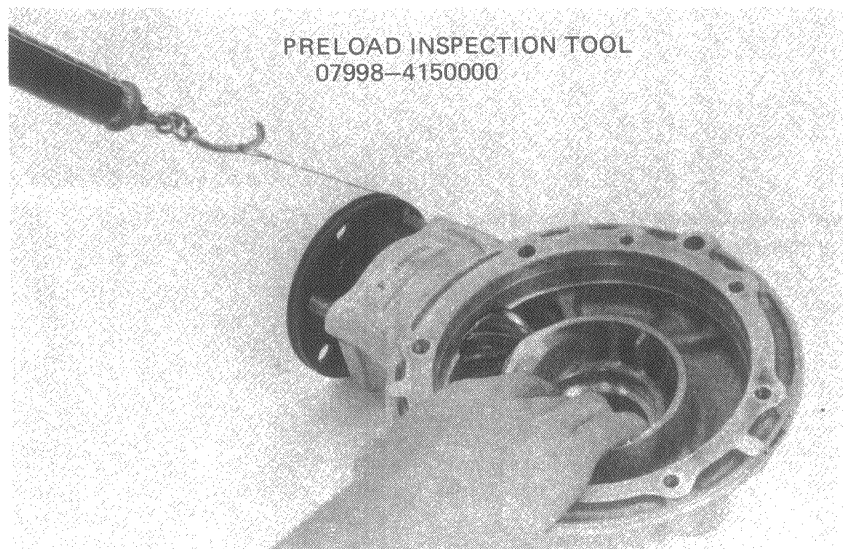



Install the preload retainer B lock tab.

NOTE

The lock tabs are available in two types.
Be sure to use the proper type lock tab.

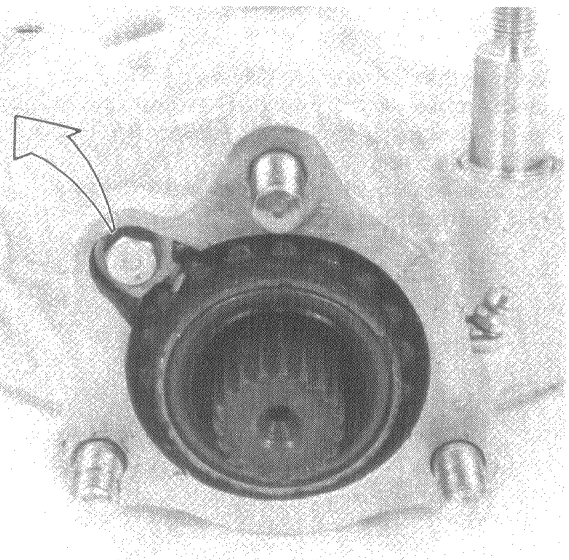
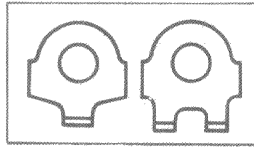

• **RING GEAR INSTALLATION**

Clean all sealing material off the mating surfaces of the gear case and cover.

NOTE

- Prevent dust and dirt entering the gear case.
- Do not damage the mating faces of the gear case and cover.

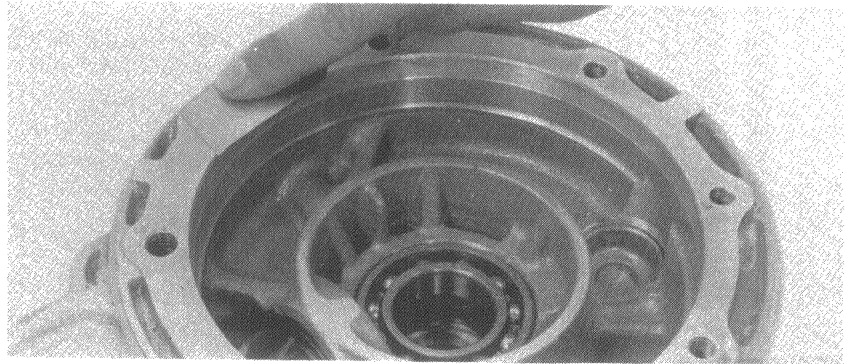

Clean the cover mating surface of the gear case with an oil stone.

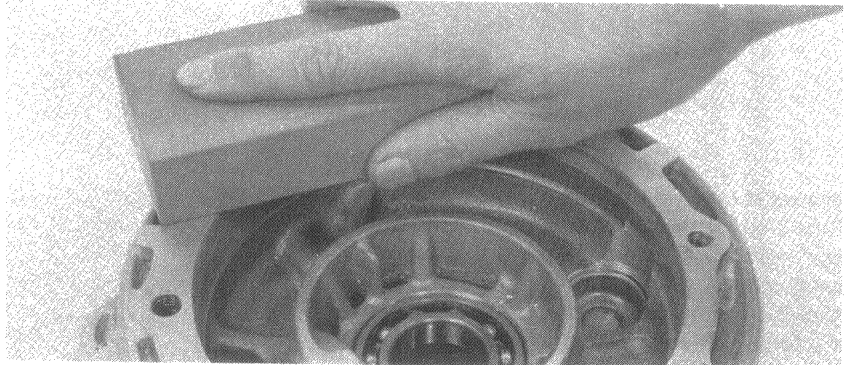

Apply liquid sealant to the mating surfaces of the gear case and cover.

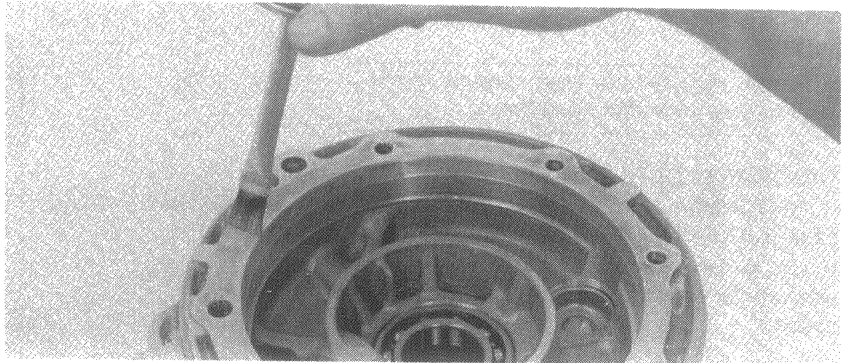



Apply a thin coating of Prussian Blue to the pinion gear teeth for gear tooth contact pattern check, prior to installing the ring gear.

Assemble the ring gear shim and ring gear in the gear case. Install the left gear case cover.

NOTE

Do not allow the left gear case cover to tilt during installing.

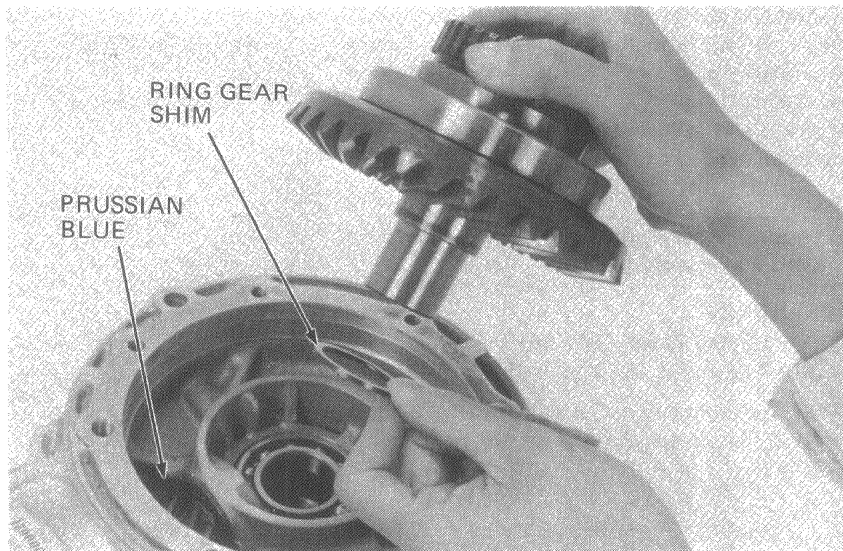

Tighten the three cover bolts showing the sign \uparrow in 2-3 steps until the left gear case cover touches the gear case. Torque to the specified tension in a cross pattern in two or more steps.

TORQUE SPECIFICATION:

8 mm bolt: 2.3–2.8 kg-m (17–20 ft-lbs)

10 mm bolt: 3.5–4.5 kg-m (25–33 ft-lbs)

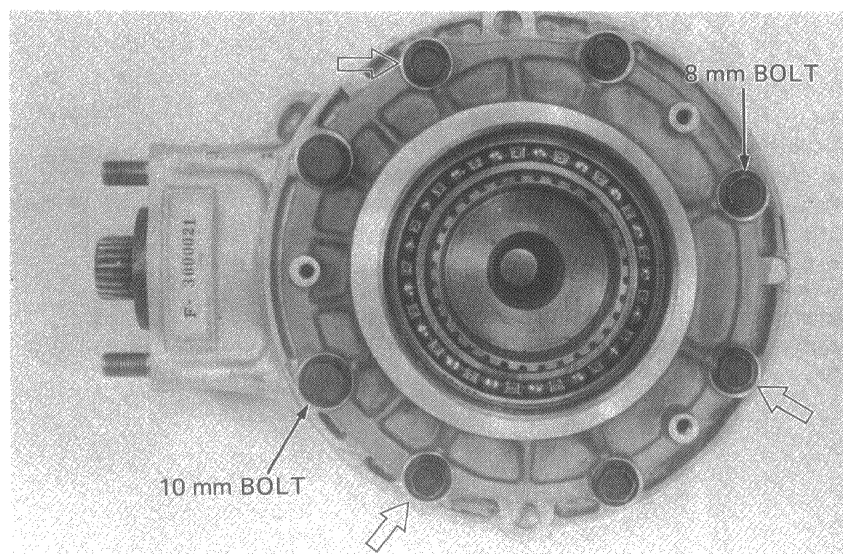

Install the preload retainer A with the oil seal and O-ring assembled in the retainer.

Before the retainer bottoms against the bearing, measure the torque T to overcome the friction caused by the O-ring.

Tighten the retainer to T + 4.0 kg-m (T + 29 ft-lbs) back-off, and retorque to T + 1.0 kg-m (T + 7 ft-lbs).

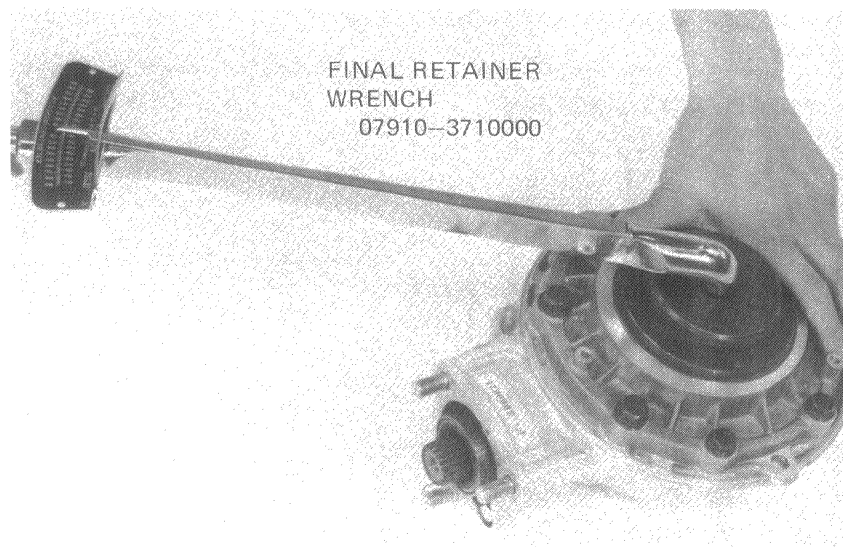

NOTE

After assembling the final gear case, perform the following operations:

- Backlash inspection
- Final gear preload check
- Final gear tooth contact pattern check



Inspect the assembly preload.

Run a string through a bolt hole in the pinion gear holder and wind it around the outside of the groove.

Attach a spring scale to the string and measure the force needed to turn the holder.

NOTE

Torque required to begin pinion movement may exceed preload limits.

REFERENCE

1,200–1,800 g (2.65–3.97 lbs)

[6.0–9.0 kg-cm (5.16–7.80 in-lbs)]

If the assembly preload is out of specifications, reinstall the pinion and recheck the preload.

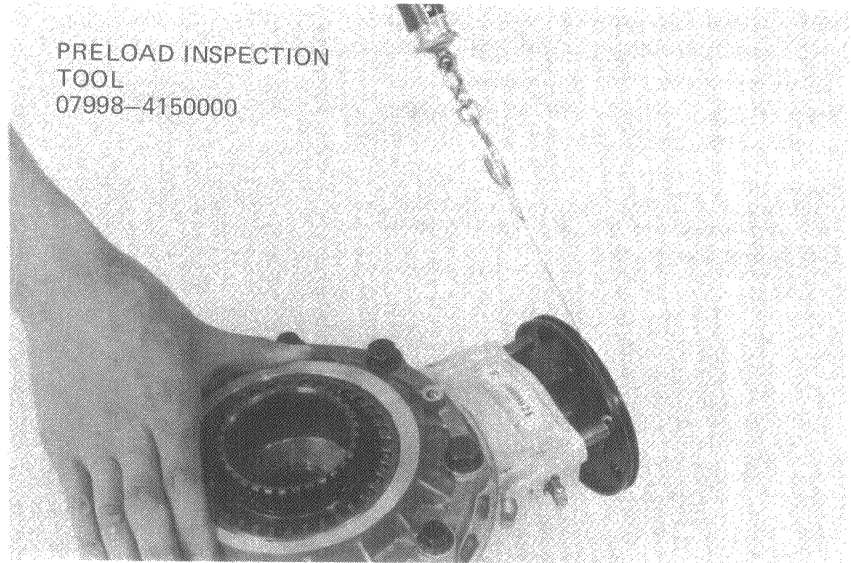

• **GEAR TOOTH CONTACT PATTERN CHECK**

Remove the oil filler cap from the final gear case.

Check the gear tooth contact pattern by rotating the ring gear several times in the normal direction of rotation. The gear tooth contact pattern is indicated by Prussian Blue applied to the pinion before assembly.

Contact is normal if the Prussian Blue is transferred to the approximate center of each tooth flank slightly extending toward the toe side.

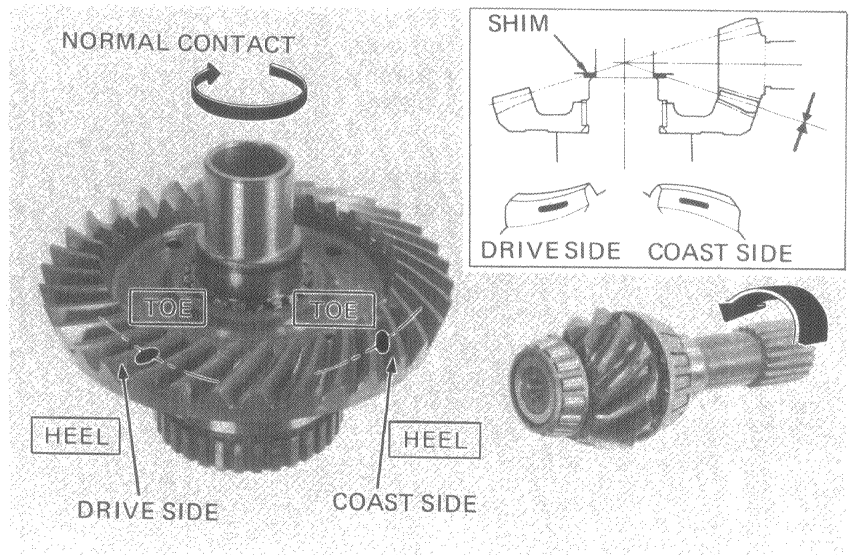

Replace the ring gear shim, if the patterns are not correct.

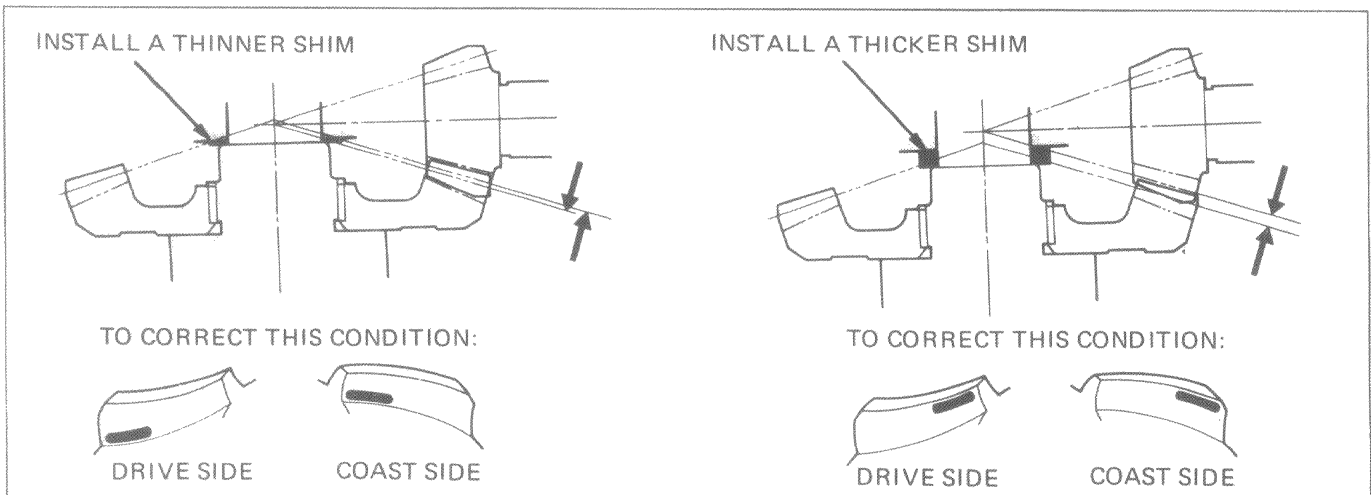



Install the dust plate and torque the bolts.
 Bend the tabs of the lock plates up to prevent the bolts from being turned out during operation.
 Bend one of the four bearing retainer A lock tabs.

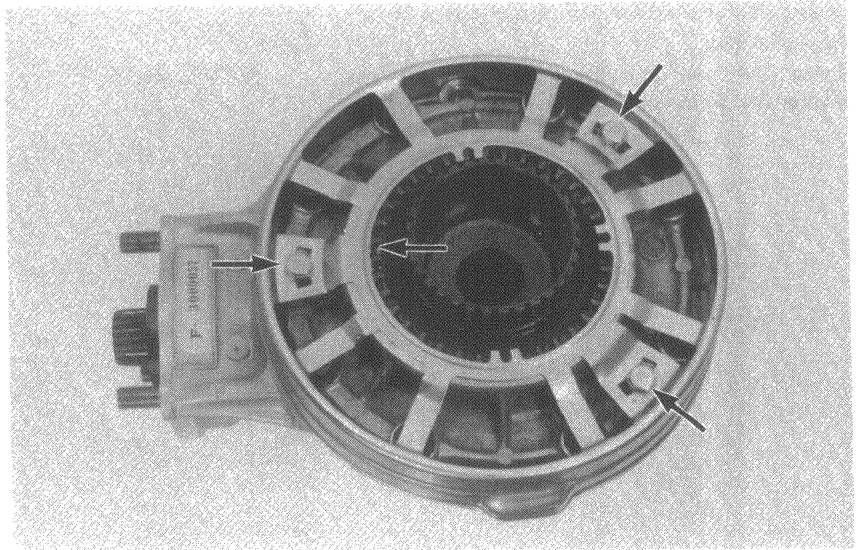

● FINAL GEAR CASE INSTALLATION

Lubricate the splines of the propeller shaft and pinion gear shaft with lithium-based multipurpose grease, and engage.

Temporarily install the gear case on the swing arm and rear shock absorber.

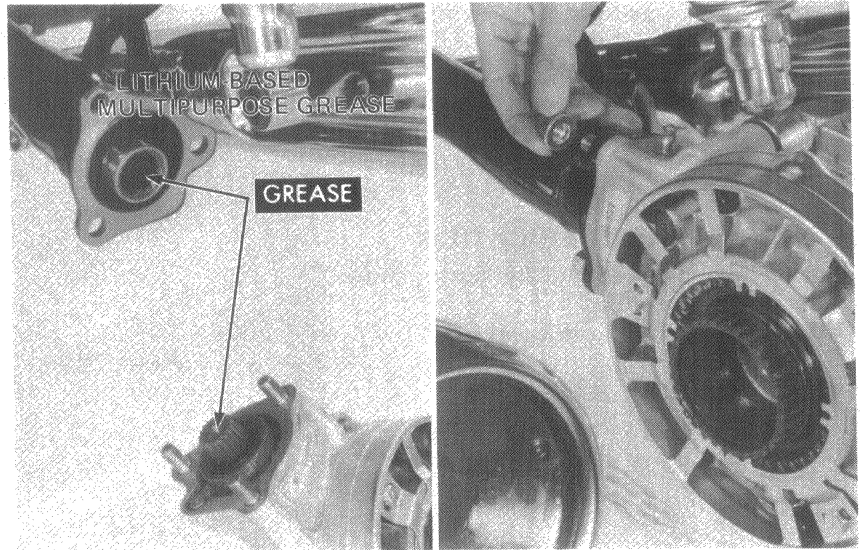

Apply lithium-based multipurpose grease to the splines of the rear wheel and ring gear shaft.
 Insert the distance collar into the ring gear shaft in the direction shown.

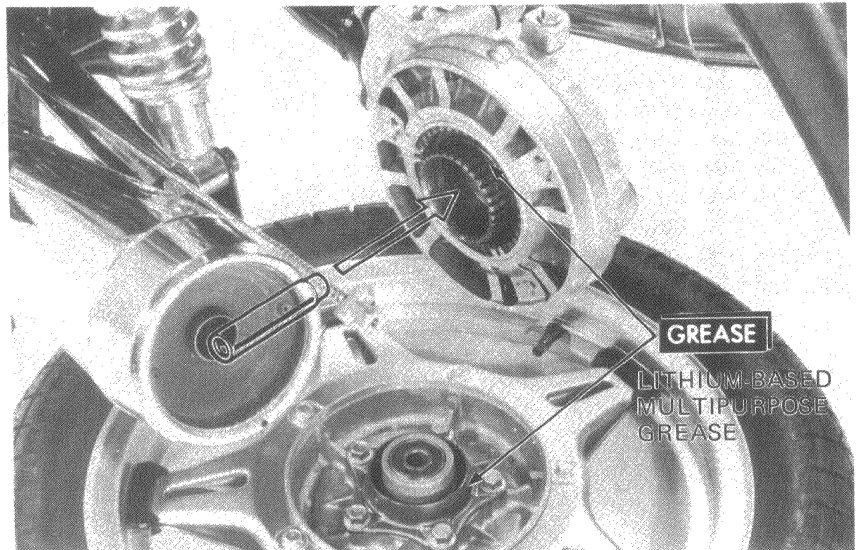



Install the rear wheel and brake panel on the final gear case.

Insert the rear axle through the swing arm, washer, brake panel and rear wheel.

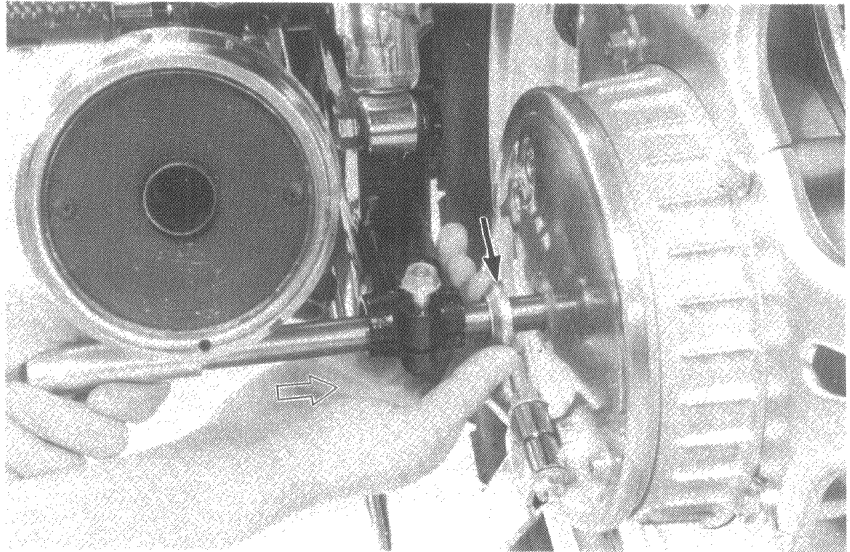

Torque the final gear case to the swing arm and shock absorber mounting nut.

TORQUE SPECIFICATION:

REAR FORK: 4.5–6.0 kg-m (33–44 ft-lbs)

**REAR SHOCK: 3.0– 4.0 kg-m
(22– 29 ft-lbs)**

Install the rear wheel. (Page 14–8)

● **PINION GEAR LUBRICATION**

Pump lithium-based multipurpose grease through the grease fitting.

GREASE QUANTITY: 45 cc approx.

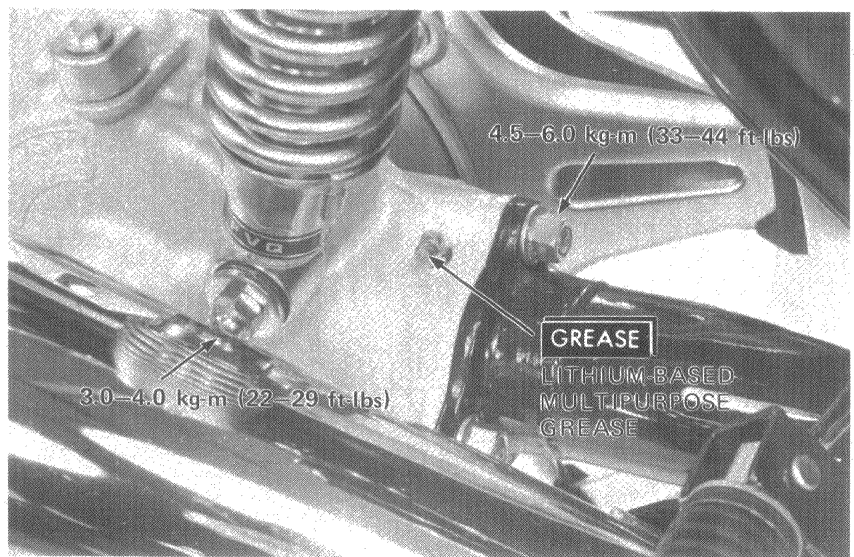

● **FILLING FINAL GEAR CASE**

Place the motorcycle on its center stand.

Make sure that the drain bolt is tightened.

Remove the oil filler cap.

Pour the specified amount of recommended oil up to the filler neck.

RECOMMENDED OIL: HYPOID GEAR OIL

Over 5°C: SAE 90

Below 5°C: SAE 80

OIL CAPACITY: 160–180 cc

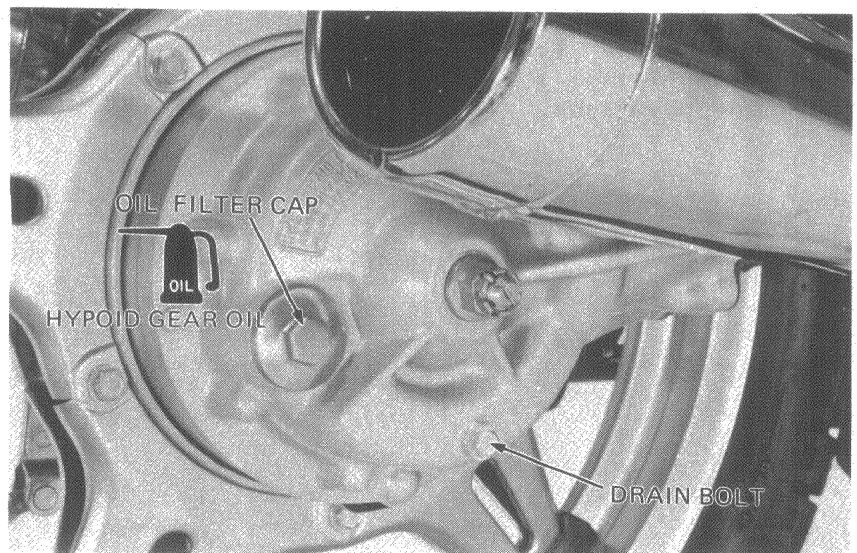



REAR FORK / PROPELLER SHAFT

● **SWING ARM/PROPELLER SHAFT
REMOVAL**

Remove the rear wheel. (Page 14-3)
Remove the final gear case. (Page 14-12)
Slide the boot backward and remove the propeller shaft joint bolt.
Remove the propeller shaft from the engine.
Remove the left shock absorber.

CAUTION

Pump grease into the final gear case through the grease nipple whenever the propeller shaft is removed from the engine.

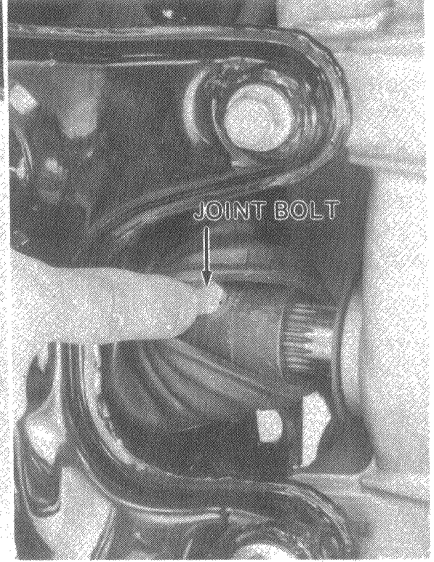
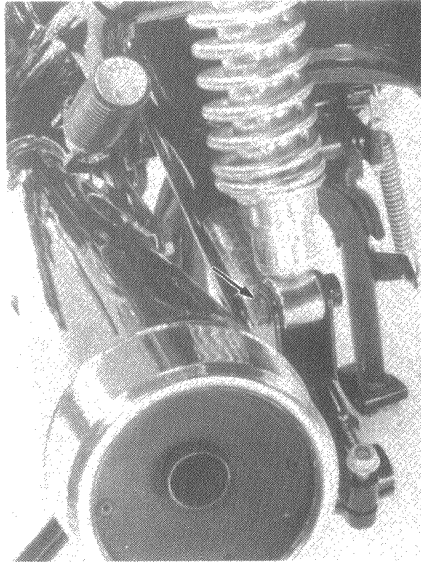

Remove the swing arm pivot bolt from the left.

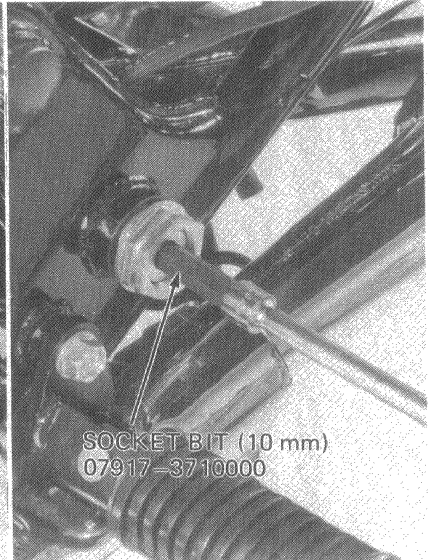
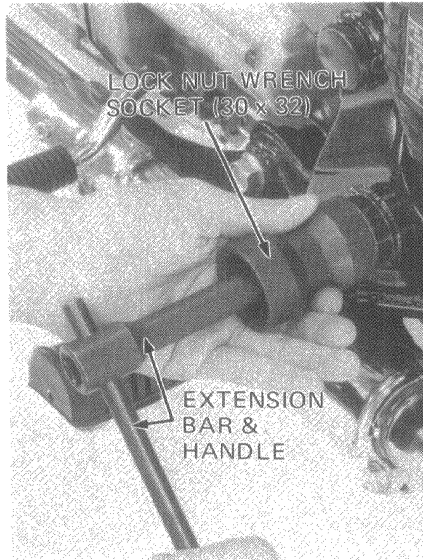

Free the drain tube, etc. from the clamps.
Remove the right pivot.
Remove the swing arm and propeller shaft.

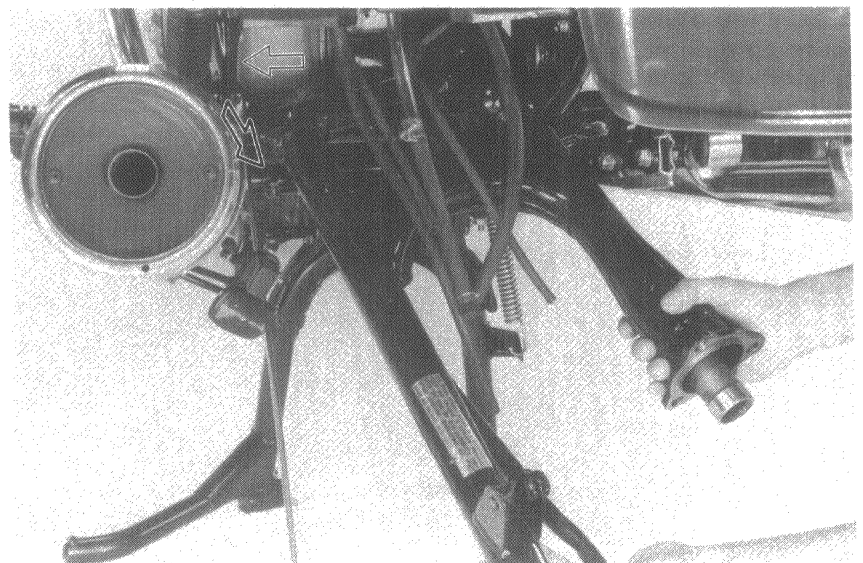



● PROPELLER SHAFT INSPECTION

Remove the boot from the swing arm.
Remove the drive shaft from the swing arm and inspect the universal joint splines.

Inspect the universal joint. There should be no play in the universal joint bearings.
Rotate the shaft and joint in opposite directions. If there is any evidence of side play, the shaft must be replaced.

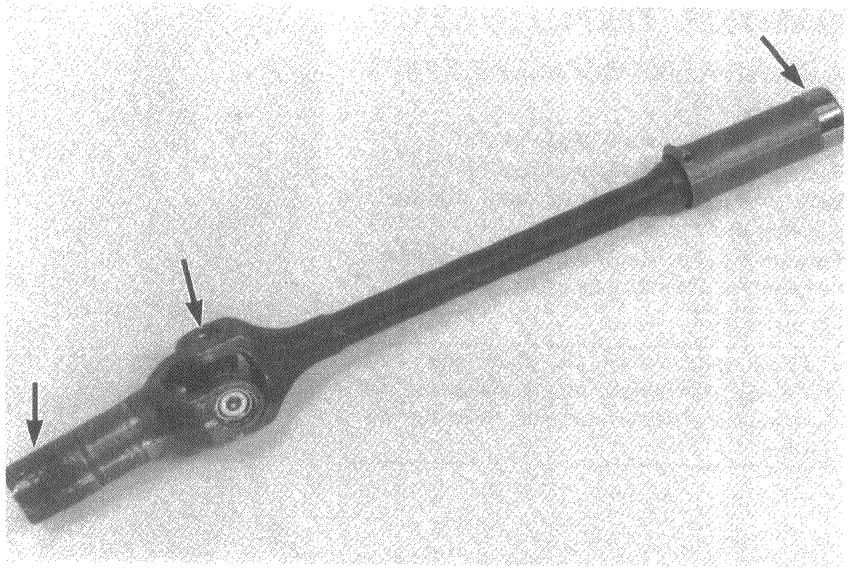

Drive out the spring pin.
Separate the drive shaft joint from the drive shaft.

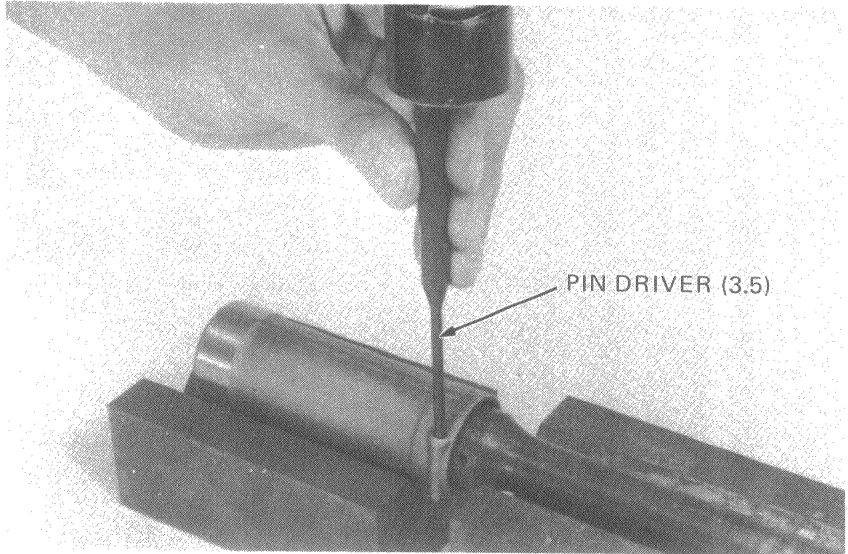

Inspect the drive shaft and drive shaft joint splines for wear and damage.
Lubricate the splines with lithium-based multipurpose grease.
Assemble the drive shaft and drive shaft joint and drive in the spring pin.

NOTE

The spring pin should be below the drive shaft joint.

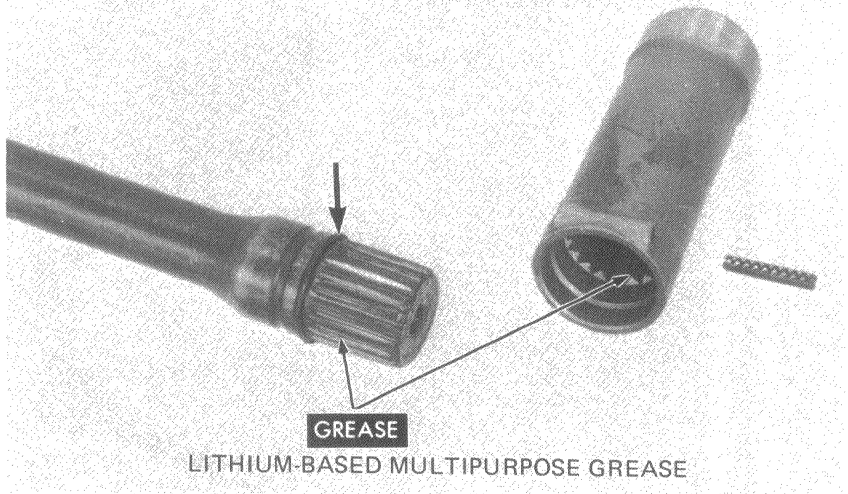



● **PIVOT BEARING INSPECTION
(LEFT SIDE)**

Cut away the sealing plate using a 12 mm (1/2 in.) drill bit.
Set the special tool as shown.

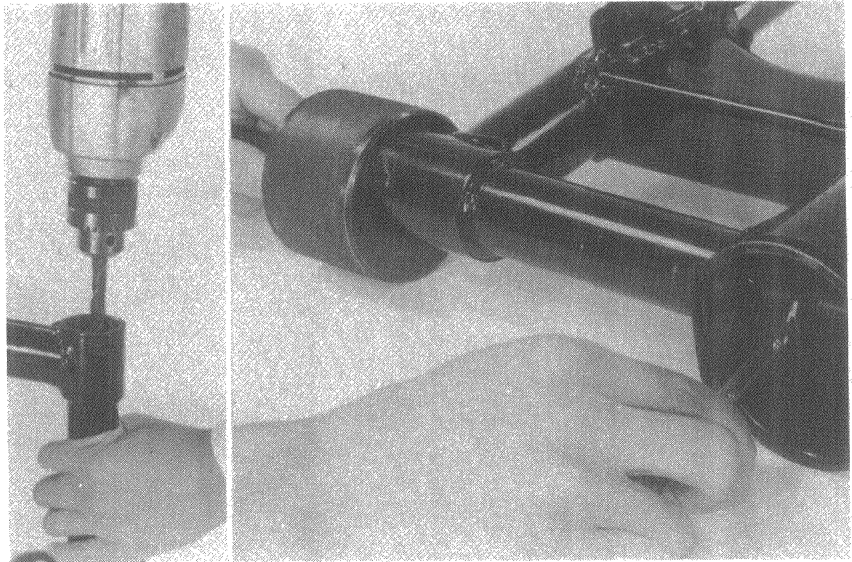

Remove the bearing outer.

NOTE

Do not allow the handle to tilt when removing the bearing outer.

Remove the remaining sealing plate and metal saw dust.

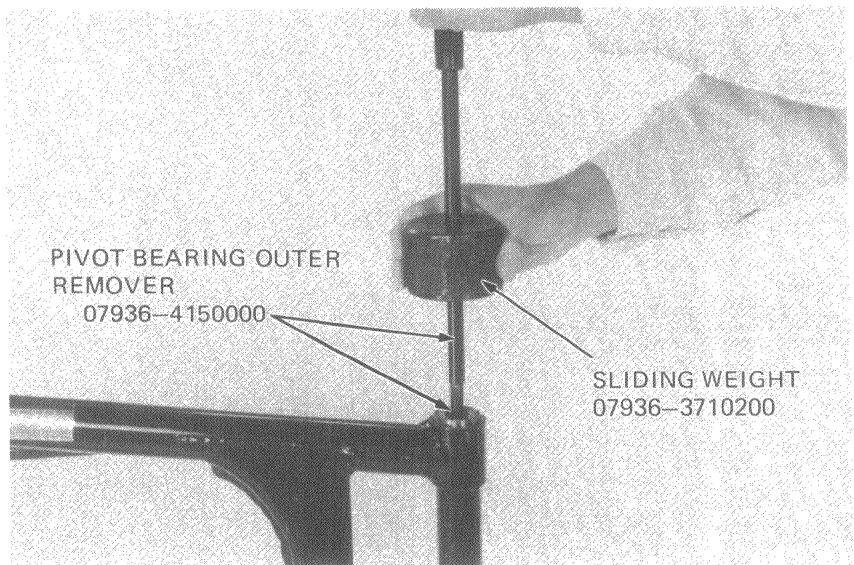

Install a new sealing plate.

CAUTION

Install the plate with the dished end facing up.

Install a new bearing outer.

CAUTION

Install the bearing outer squarely.

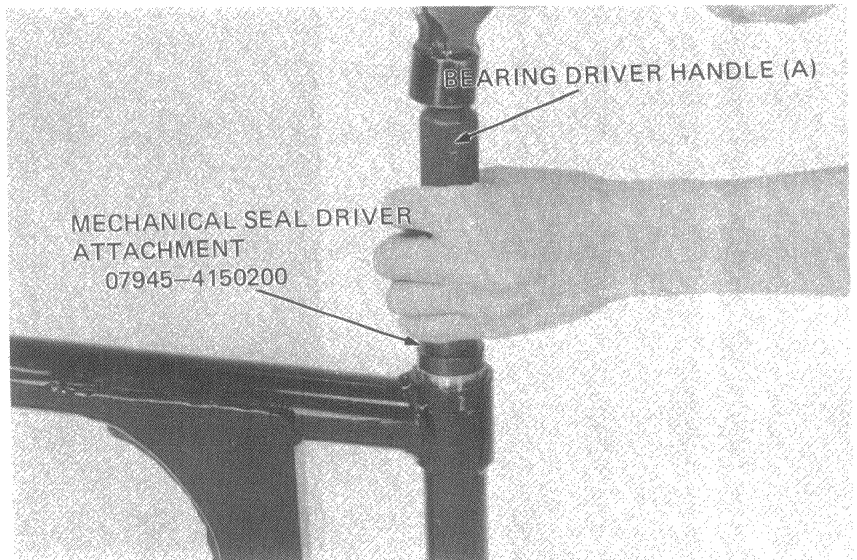



• PIVOT BEARING REPLACEMENT
(RIGHT SIDE)

Remove the cap and drive the pivot bearing holder out.

CAUTION

Lightly tap the holder with a hammer.

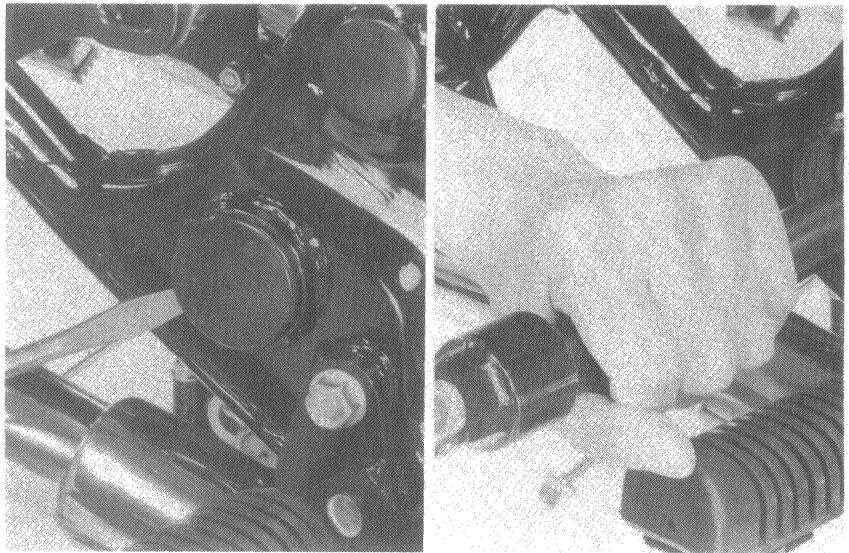

If the bearing outer or inner is damaged, replace it with a new one.

NOTE

The bearing inner and outer must be replaced as a set.

Drive the bearing outer into the bearing holder.

NOTE

Drive the bearing outer squarely.

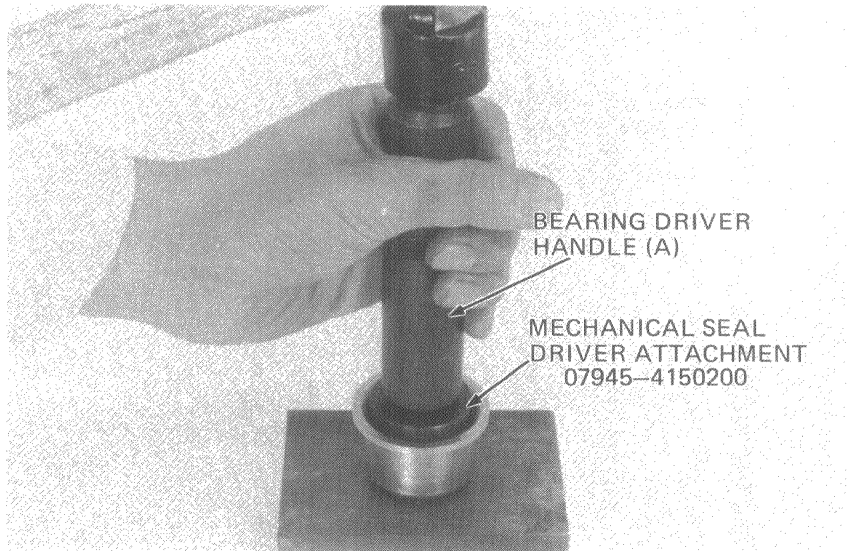

Install the bearing holder so that the flange is seated against the frame body.
Pack all bearing cavities with grease; apply grease to the oil seal lip.
Install the bearing and oil seal in the bearing holder.

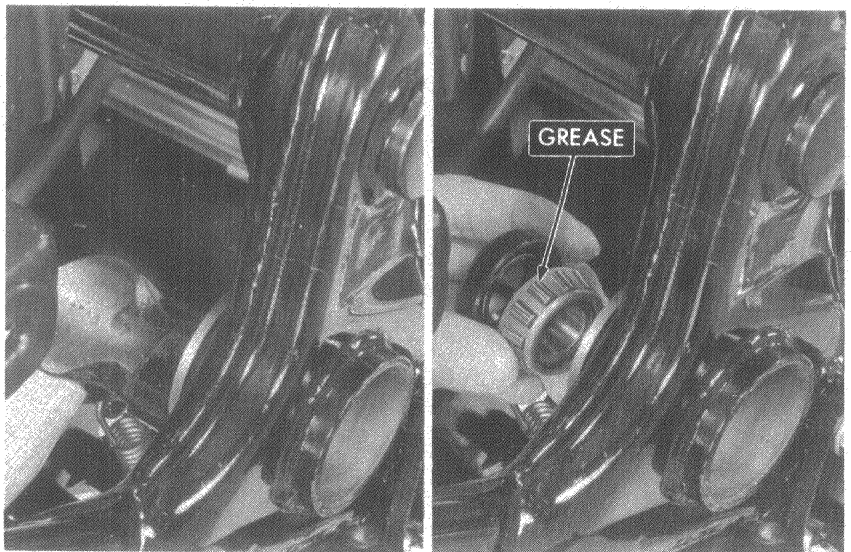



- SWING ARM/PROPELLER SHAFT INSTALLATION

Install the fork pivot nut from the inside.

NOTE

Align with the tab of the fork pivot nut.

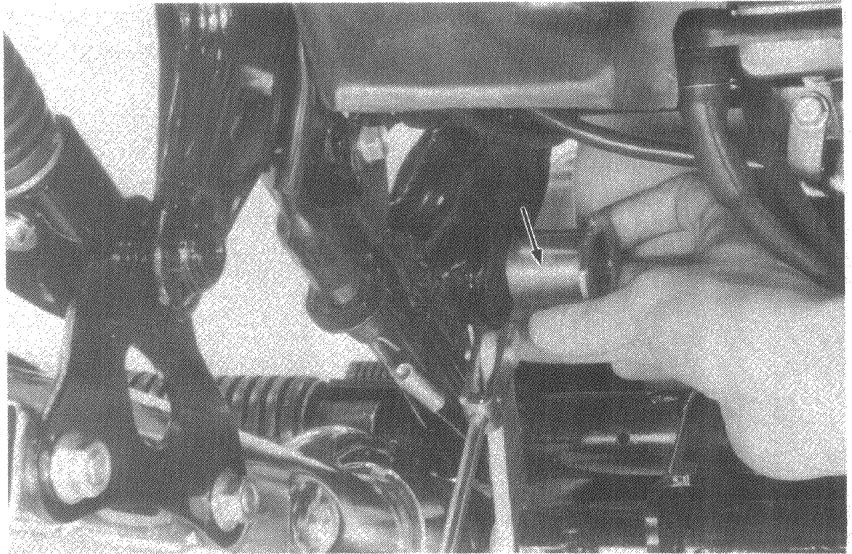

Install the brake torque link on the swing arm.
Insert the propeller shaft through the swing arm
and install the boot.

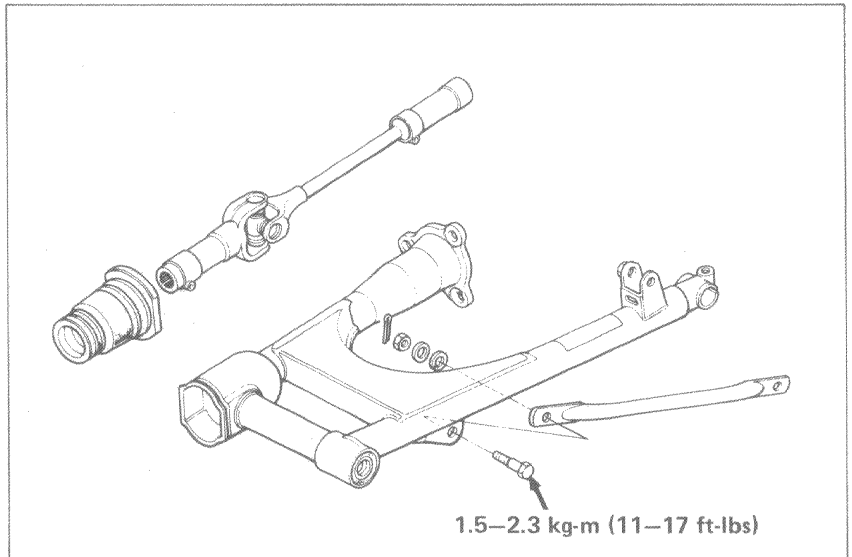

Install the right pivot in the bearing inner.

NOTE

Make sure that the right pivot oil seal is
installed properly.

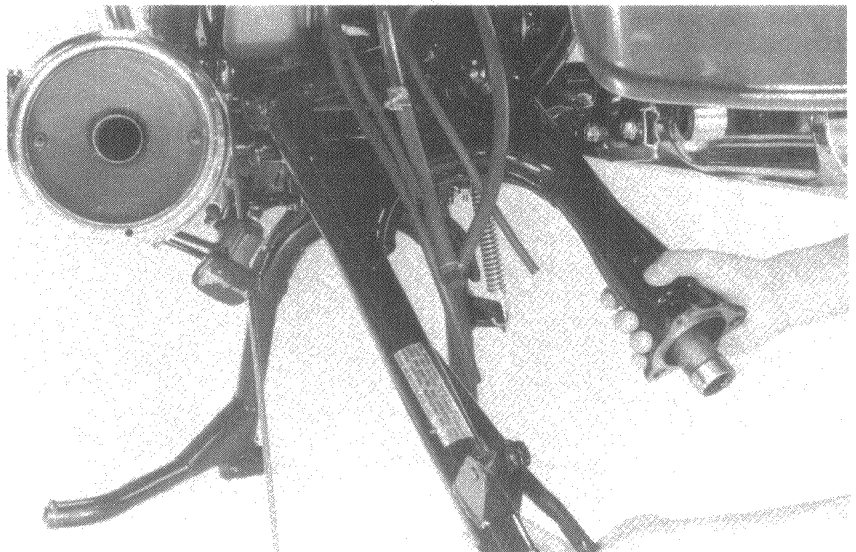



Install the swing arm on the pivot bearing holder from the right side.

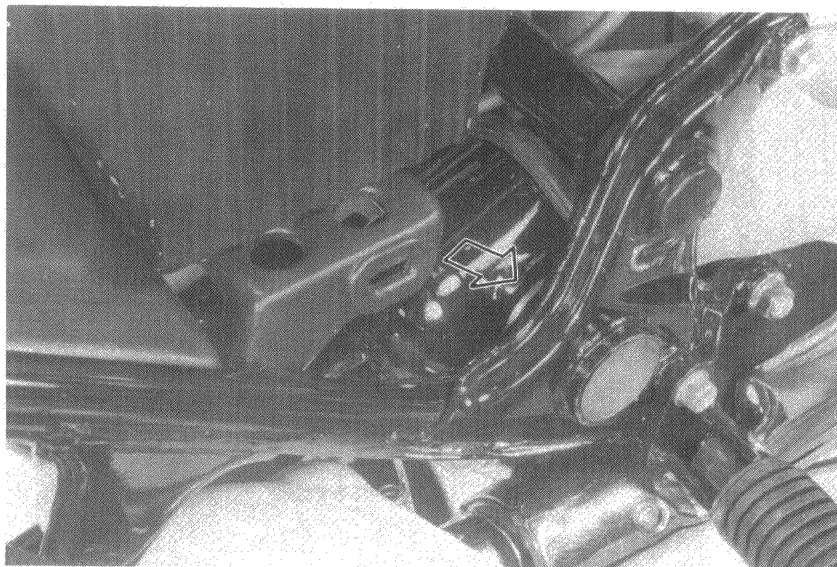

Tighten the pivot bolt gradually.

NOTE

Make sure that the end of the pivot bolt is inserted into the bearing inner.

Torque the swing arm pivot bolt.

TORQUE SPECIFICATION:
0.8–1.2 kg-m (6–9 ft-lbs)

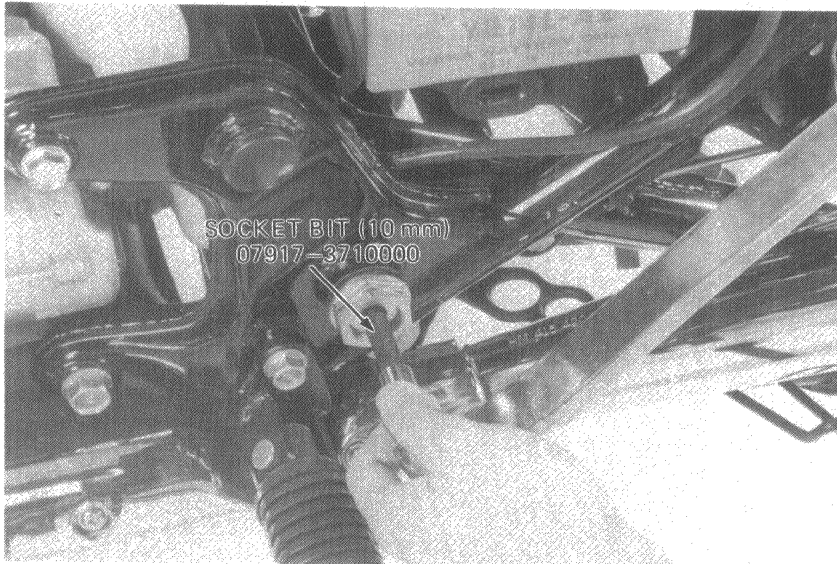

Tighten the lock nut.

TORQUE SPECIFICATION:
8.0–12.0 kg-m (58–87 ft-lbs)

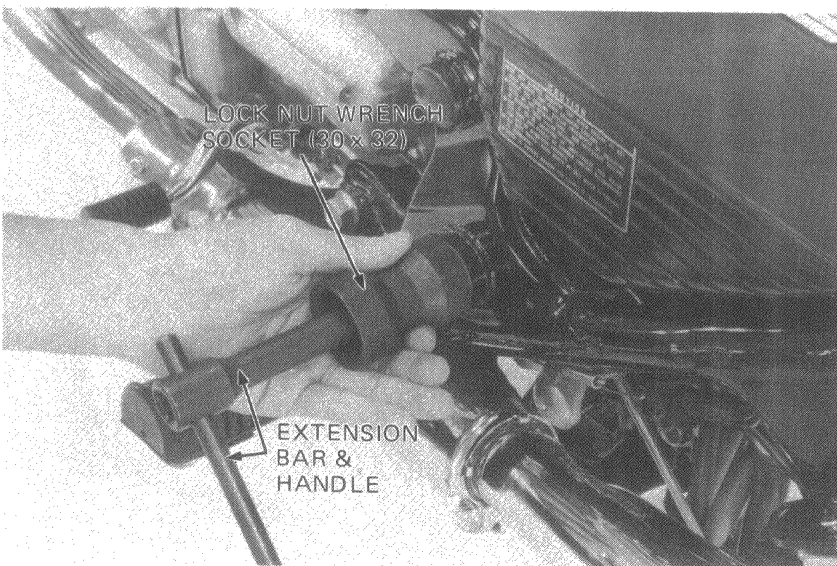



Install the dust cover.

NOTE

Align the left dust cover with the lock nut.

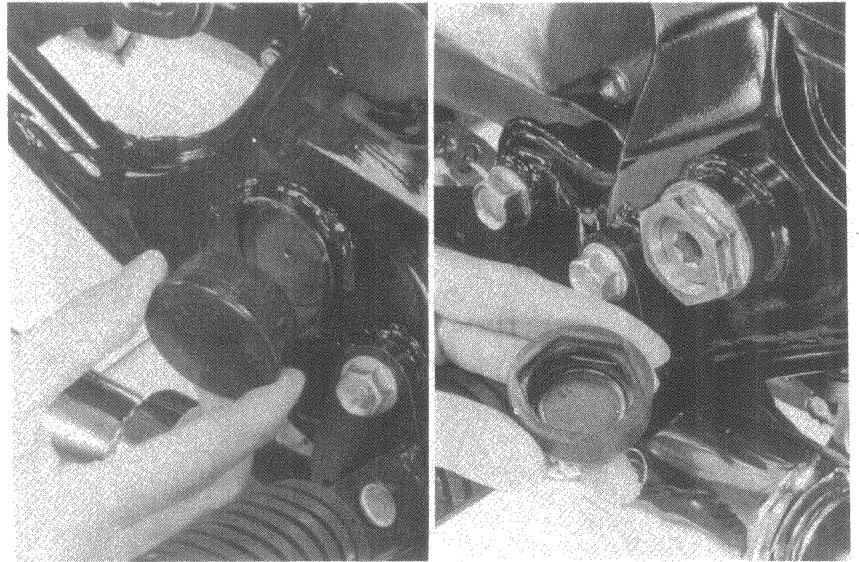

Route the drain tube etc. through the clamps.

CAUTION

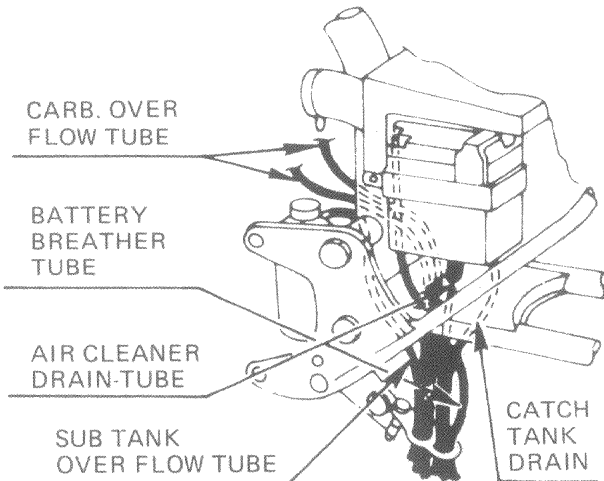

Install the shock absorber.
Lubricate the final shaft spline with lithium-based multipurpose grease.
Join the drive shaft and install the boot securely.

WARNING

Check that the final shaft does not appear more than 10 mm.

Install the final drive gear case. (Page 14-21)
Install the rear wheel. (Page 14-8)

CAUTION

After installing the final drive case, pump 45 cc of lithium-based multipurpose grease through the grease fitting.

